

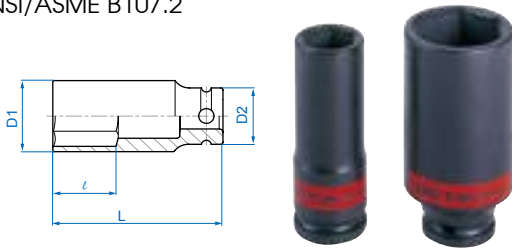



Impact Thin Wall Socket

- Material - chrome molybdenum alloy steel
- Finishing - phosphate sunk

4935S  1/2"

- ANSI/ASME B107.2



KT NO.	⌀ inch	D1 mm	D2 mm	l mm	L mm			
493510S	5/16	13.0	25	20	80	129	6	120
493512S	3/8	16.0	25	20	80	145	6	120
493514S	7/16	16.7	25	20	80	148	6	120
493516S	1/2	19.0	25	20	80	159	6	120
493518S	9/16	20.5	25	20	80	165	6	120
493520S	5/8	23.0	25	20	80	170	6	120
493522S	11/16	24.5	30	23	80	235	6	96
493524S	3/4	27.0	30	23	80	255	6	96
493526S	13/16	29.0	30	25	80	292	6	96
493528S	7/8	30.5	30	25	80	308	5	60
493530S	15/16	33.0	30	26	80	336	5	60
493532S	1	34.0	30	26	80	356	5	60
493534S	1-1/16	37.0	30	27	80	405	5	60
493536S	1-1/8	39.0	30	27	80	414	5	50
493538S	1-3/16	40.5	30	27	80	417	5	50
493540S	1-1/4	42.5	30	27	80	422	5	50



Extra Thin Wall Impact Socket

- Finishing - phosphate sunk
- For aluminum alloy wheel
- Material - chrome molybdenum alloy steel
- Super thin wall version has less strength than standard deep one

4415M  1/2"

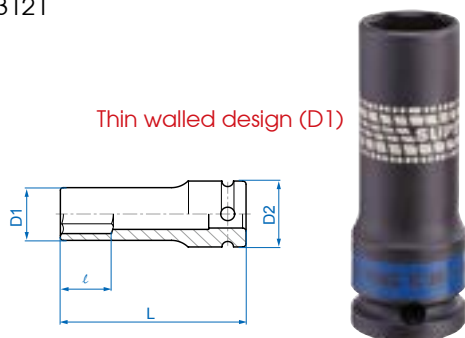
- DIN 3121



KT NO.	⌀ mm	D1 mm	D2 mm	l mm	L mm			
441517M	17	23.8	25	17	80	171	6	96
441519M	19	25.8	30	20	80	209	6	96
441521M	21	27.8	30	22	80	219	6	96
441522M	22	29.5	30	24	80	237	6	96



Wheel Nut Impact Socket

- Material - chrome molybdenum alloy steel
- Finishing - phosphate sunk
- Durable outer sleeve protects polished wheels and lug nut

4945MX  1/2"

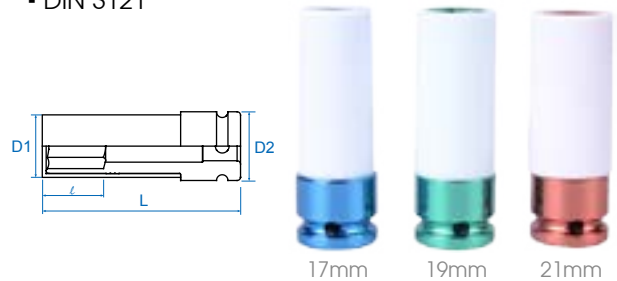
- DIN 3121







KT NO.	⌀ mm	D1 mm	D2 mm	l mm	L mm			
494517MX	17	27.3	30	26	85	214	5	60
494519MX	19	29.3	30	26	85	229	5	60
494521MX	21	30.9	30	26	85	237	5	60

Impact Star Socket

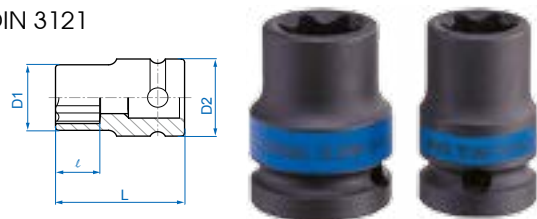
4575M  1/2"

- For torx external screw
- DIN 3121



KT NO.	Star Size	D1 mm	D2 mm	l mm	L mm			
457510M	E10	14.0	25.0	7.5	38	67	10	200
457512M	E12	15.9	25.0	9.0	38	69	10	200
457514M	E14	17.7	25.0	10.0	38	71	10	200
457516M	E16	20.0	25.0	11.0	38	76	10	200
457518M	E18	22.0	25.0	12.5	38	79	10	200
457520M	E20	24.5	30.0	14.0	38	118	10	160