

# 1/2" DR. RATCHET WRENCH

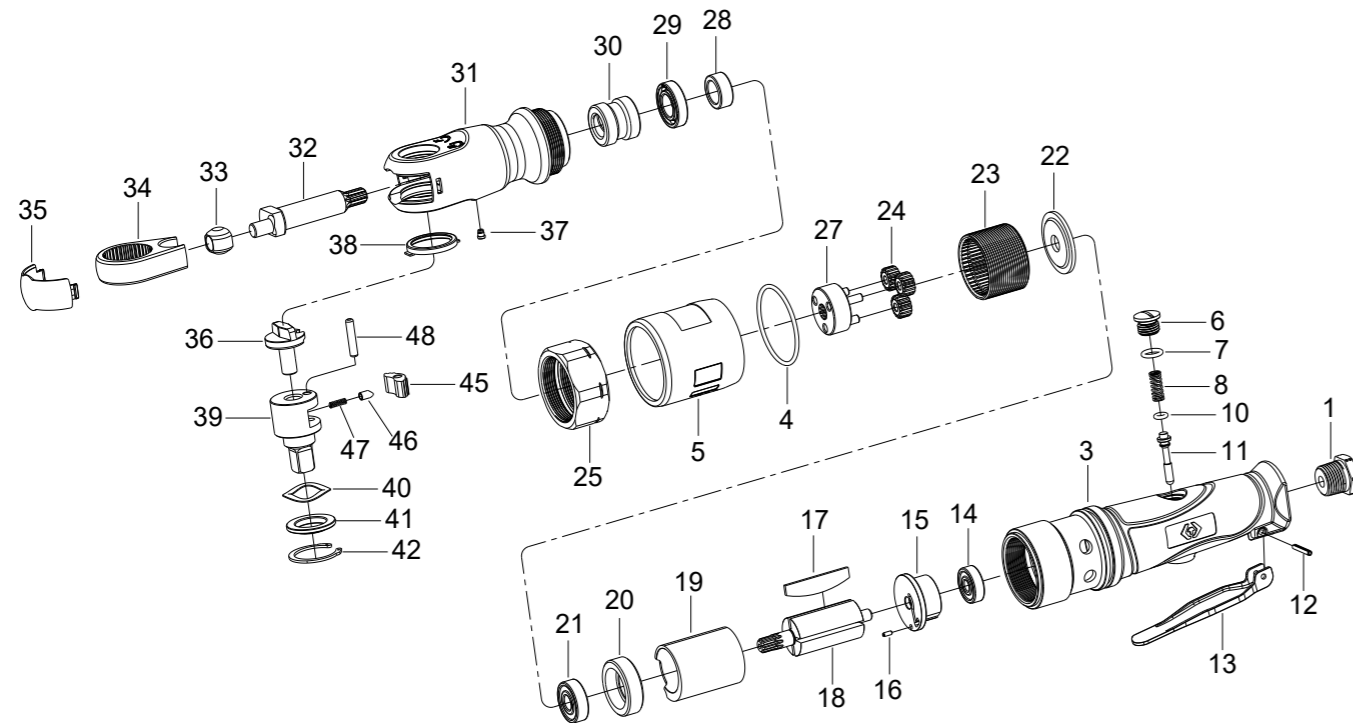

NO.37434-080  
37434-081



INDEX NO.	KT No.	DESCRIPTION	REQ'D NO.	INDEX NO.	KT No.	DESCRIPTION	REQ'D NO.
1	037434-A01	Air Inlet ( for 19 BSPT )	1	27	037434-A27	Work Spindle Assembly	1
1A	037434-A01A	Air Inlet ( for 18 NPT )	1	28	037434-A28	Spacer	1
3	037434-A03	Motor Housing	1	29	037434-A29	Bearing	1
4	037434-A04	O-Ring	1	● 30	037434-A30	Bushing	1
5	037434-A05	Exhaust Deflector	1	★ 31	037434-A31	Ratchet Housing Assembly ( incl. 30.37 )	1
6	037434-A06	Air Regulator	1	32	037434-A32	Crank shaft	1
7	033111-A40	O-Ring	1	33	037423-A39	Drive Bushing	1
8	037434-A08	Spring	1	34	037423-A40	Ratchet Yoke	1
10	037221-A11	O-Ring	1	35	037434-A35	Ratchet Housing Cover	1
11	037434-A11	Throttle Valve Plunger	1	36	037434-A36	Reverse Knob	1
12	037434-A12	Pin	1	● 37	037221-A52	Grease Fitting	1
13	037434-A13	Trigger	1	38	037423-A43	Thrust Washer	1
14	037423-A24	Bearing	1	39	037434-A39	Ratchet Anvil Assembly	1
15	037434-A15	End Plate	1	40	037423-A52	Wave Washer	1
16	037434-A16	Pin	1	41	037423-A51	Thrust Washer	1
17	037434-A17	Rotor Blade	4	42	037423-A53	Retaining Ring	1
18	037434-A18	Rotor	1	45	037423-A50	Ratchet Pawl	1
19	037434-A19	Cylinder	1	46	037423-A49	Ratchet Lock Pin	1
20	037434-A20	End Plate	1	47	037423-A48	Ratchet Spring	1
21	037434-A21	Bearing	1	48	033421-A09	Pin	1
22	037434-A22	Washer	1	TK-01	037434-ATK1	Ratchet Anvil Assembly ( incl. 36.39.45.46.47.48 )	
23	037434-A23	Ring Gear	1	TK-02	037434-ATK2	End Plate Assembly ( incl. 14.15.16 )	
24	037434-A24	Planet Gear	3	TK	037434-ATK	Tune-Up Kit ( incl. 4.7.8.10 )	
25	037434-A25	Coupling Nut	1				

★ Must be purchased in assembly set

● Recommended not to be purchased alone due to assembly difficulty

20140124R2

Inspec. Item No.	Square drive		Std. Bolt Size		Free Speed		MAX. Torque		Overall Length		Air Inlet		Air Hose		Avg. Air Consumption		Net Weight		Sound Pressure Level A-weighted	Sound Power Level A-weighted	Sound Pressure Valve Peak C-weighted	Vib. M/S <sup>2</sup>
	inch	mm	inch	mm	RPM	ft-lb	N.m	inch	mm	BSPT/NPT	ID	cm	l/min	lbs	kgs	dB	dB					
37434-080	1/2	3/8	M10	210	80	108	10-39/64	268	1/4" BSPT	3/8	4.5	127	2.78	1.26	92.00	103.00	107.00	3.91				
37434-081	1/2	3/8	M10	210	80	108	10-39/64	268	1/4" NPT	3/8	4.5	127	2.78	1.26	92.00	103.00	107.00	3.91				

http : //www.kingtony.com 8937434080-KT 192x288mm



**KING TONY TOOLS CO., LTD.**  
No. 11, Alley 150, Lane 516, Sec. 2, Hsi Nan Rd.,  
Wu-Jih Dist., Taichung City, Taiwan  
Tel : 886-4-2335-3567 Fax : 886-4-2335-3642

**EC DECLARATION OF CONFORMITY  
FOR NON-ANNEX IV MACHINERY  
IN ACCORDANCE WITH  
MACHINERY SAFETY DIRECTIVES**

2006 / 42 / EC

**IMPACT WRENCH  
OPERATOR'S INSTRUCTION**

This impact wrench has the CE approval

WE, **KING TONY TOOLS CO., LTD.** HEREBY CERTIFY THAT THE MACHINERY DESCRIBED BELOW CONFORMS WITH THE ESSENTIAL HEALTH AND SAFETY REQUIREMENTS OF MACHINERY SAFETY DIRECTIVES 2006/42/EC ON THE APPROXIMATION OF THE LAWS OF THE MEMBER STATES RELATING TO THE SAFETY OF MACHINERY,

**IMPACT WRENCH**

**37434-080**

AND COMPLY WITH THE PROVISIONS SET OUT IN THE FOLLOWING EUROPEAN STANDARD:

ISO 12100:2010 (RISK ASSESSMENT & RISK REDUCTION)

ISO 11148-6:2012 (SAFETY REQUIREMENTS)

ISO 15744:2002 (NOISE LEVEL)

ISO 28927-2:2009 (VIBRATION LEVEL)

DATE OF ISSUE: 7<sup>th</sup> January 2014

NAME: Lin Hsien-Wen

POSITION/TITLE: General manager

SIGNATURE: *Lin Hsien-Wen*



# 1/2" DR. RATCHET WRENCH



NO.37434-080  
37434-081

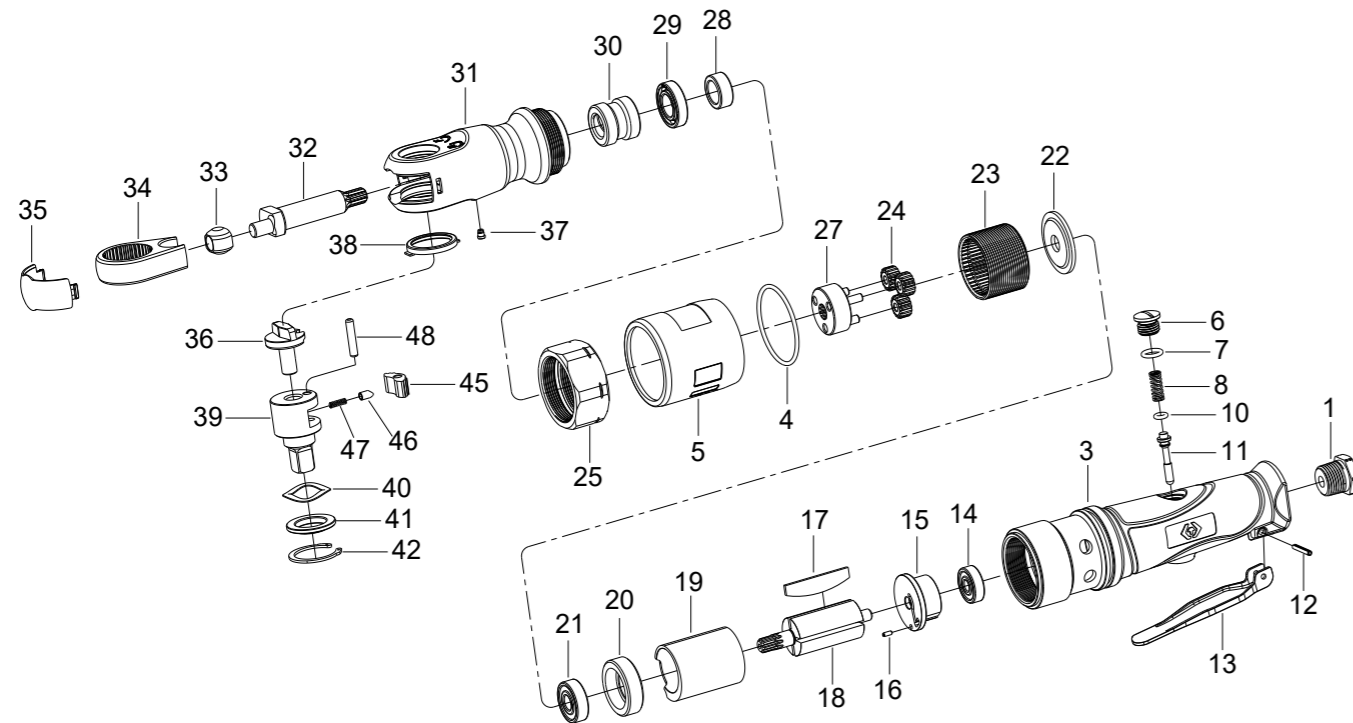

INDEX NO.	KT No.	DESCRIPTION	REQ'D NO.	INDEX NO.	KT No.	DESCRIPTION	REQ'D NO.
1	037434-A01	Air Inlet ( for 19 BSPT )	1	27	037434-A27	Work Spindle Assembly	1
1A	037434-A01A	Air Inlet ( for 18 NPT )	1	28	037434-A28	Spacer	1
3	037434-A03	Motor Housing	1	29	037434-A29	Bearing	1
4	037434-A04	O-Ring	1	● 30	037434-A30	Bushing	1
5	037434-A05	Exhaust Deflector	1	★ 31	037434-A31	Ratchet Housing Assembly ( incl. 30.37 )	1
6	037434-A06	Air Regulator	1	32	037434-A32	Crank shaft	1
7	033111-A40	O-Ring	1	33	037423-A39	Drive Bushing	1
8	037434-A08	Spring	1	34	037423-A40	Ratchet Yoke	1
10	037221-A11	O-Ring	1	35	037434-A35	Ratchet Housing Cover	1
11	037434-A11	Throttle Valve Plunger	1	36	037434-A36	Reverse Knob	1
12	037434-A12	Pin	1	● 37	037221-A52	Grease Fitting	1
13	037434-A13	Trigger	1	38	037423-A43	Thrust Washer	1
14	037423-A24	Bearing	1	39	037434-A39	Ratchet Anvil Assembly	1
15	037434-A15	End Plate	1	40	037423-A52	Wave Washer	1
16	037434-A16	Pin	1	41	037423-A51	Thrust Washer	1
17	037434-A17	Rotor Blade	4	42	037423-A53	Retaining Ring	1
18	037434-A18	Rotor	1	45	037423-A50	Ratchet Pawl	1
19	037434-A19	Cylinder	1	46	037423-A49	Ratchet Lock Pin	1
20	037434-A20	End Plate	1	47	037423-A48	Ratchet Spring	1
21	037434-A21	Bearing	1	48	033421-A09	Pin	1
22	037434-A22	Washer	1	TK-01	037434-ATK1	Ratchet Anvil Assembly ( incl. 36.39.45.46.47.48 )	
23	037434-A23	Ring Gear	1	TK-02	037434-ATK2	End Plate Assembly ( incl. 14.15.16 )	
24	037434-A24	Planet Gear	3	TK	037434-ATK	Tune-Up Kit ( incl. 4.7.8.10 )	
25	037434-A25	Coupling Nut	1				

★ Must be purchased in assembly set  
● Recommended not to be purchased alone due to assembly difficulty

20140124R2

Inspec. Item No.	Square drive		Std. Bolt Size		Free Speed		MAX. Torque		Overall Length		Air Inlet		Air Hose		Avg. Air Consumption		Net Weight		Sound Pressure Level A-weighted	Sound Power Level A-weighted	Sound Pressure Valve Peak C-weighted	Vib. M/S <sup>2</sup>
	inch	mm	inch	mm	RPM	ft-lb	N.m	inch	mm	BSPT/NPT	ID	cm	l/min	lbs	kgs	dB	dB					
37434-080	1/2	3/8	M10	210	80	108	10-39/64	268	1/4" BSPT	3/8	4.5	127	2.78	1.26	92.00	103.00	107.00	3.91				
37434-081	1/2	3/8	M10	210	80	108	10-39/64	268	1/4" NPT	3/8	4.5	127	2.78	1.26	92.00	103.00	107.00	3.91				

http : //www.kingtony.com 8937434080-KT 192x288mm



**KING TONY TOOLS CO., LTD.**  
No. 11, Alley 150, Lane 516, Sec. 2, Hsi Nan Rd.,  
Wu-Jih Dist., Taichung City, Taiwan  
Tel : 886-4-2335-3567 Fax : 886-4-2335-3642

**EC DECLARATION OF CONFORMITY  
FOR NON-ANNEX IV MACHINERY  
IN ACCORDANCE WITH  
MACHINERY SAFETY DIRECTIVES**

2006 / 42 / EC

**IMPACT WRENCH  
OPERATOR'S INSTRUCTION**

This impact wrench has the CE approval

WE, **KING TONY TOOLS CO., LTD.** HEREBY CERTIFY THAT THE MACHINERY DESCRIBED BELOW CONFORMS WITH THE ESSENTIAL HEALTH AND SAFETY REQUIREMENTS OF MACHINERY SAFETY DIRECTIVES 2006/42/EC ON THE APPROXIMATION OF THE LAWS OF THE MEMBER STATES RELATING TO THE SAFETY OF MACHINERY,

**IMPACT WRENCH**

**37434-081**

AND COMPLY WITH THE PROVISIONS SET OUT IN THE FOLLOWING EUROPEAN STANDARD:

ISO 12100:2010 (RISK ASSESSMENT & RISK REDUCTION)

ISO 11148-6:2012 (SAFETY REQUIREMENTS)

ISO 15744:2002 (NOISE LEVEL)

ISO 28927-2:2009 (VIBRATION LEVEL)

DATE OF ISSUE: 7<sup>th</sup> January 2014

NAME: Lin Hsien-Wen

POSITION/TITLE: General manager

SIGNATURE: *Lin Hsien-Wen*

