

3/8" DR. RATCHET WRENCH

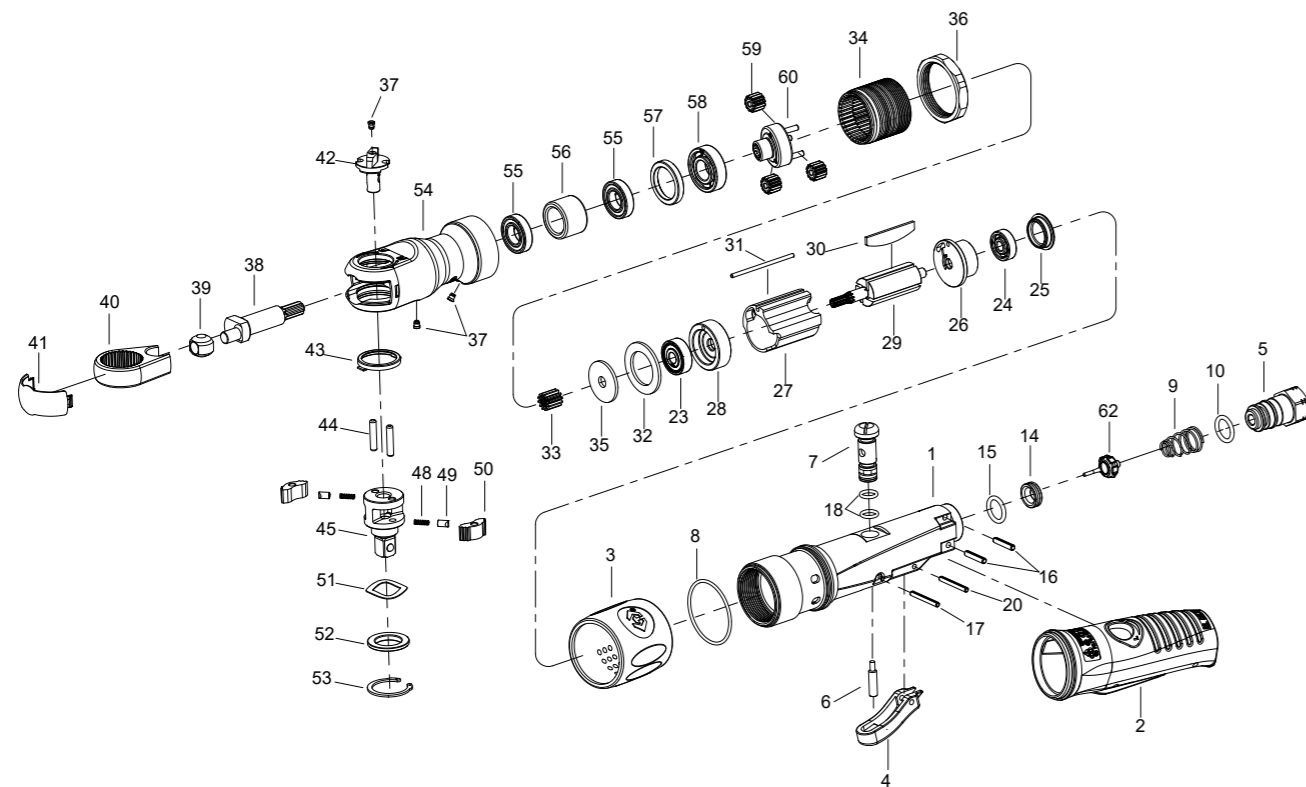

NO.37323-080
37323-081



INDEX NO.	KT No.	DESCRIPTION	REQ'D NO.	INDEX NO.	KT No.	DESCRIPTION	REQ'D NO.
1	037423-A01	Motor Housing	1	34	037423-A34	Ring Gear	1
2	037423-A02	Rubber Grip	1	35	037423-A35	Spacer	1
3	037423-A03	Exhaust Deflector	1	36	037423-A36	Coupling Nut	1
4	037423-A04	Trigger	1	37	037221-A52	Grease Fitting	3
5	037423-A05	Air Inlet (for 19 BSPT)	1	38	037423-A38	Crank shaft	1
5A	037423-A05A	Air Inlet (for 18 NPT)	1	39	037423-A39	Drive Bushing	1
6	037423-A06	Throttle Valve Plunger	1	40	037423-A40	Ratchet Yoke	1
7	037423-A07	Air Regulator	1	41	037423-A41	Ratchet Housing Cover	1
8	037423-A08	O-Ring	1	42	037423-A42	Reverse Knob Assembly (incl. 37)	1
9	033812-A05	Spring	1	43	037423-A43	Thrust Washer	1
10	037423-A10	O-Ring	1	44	033421-A09	Pin	2
14	033411-A02	Throttle Valve Seat	1	45	037323-A45	Ratchet Anvil Assembly	1
15	033411-A20A	O-Ring	1	48	037423-A48	Ratchet Spring	2
16	037423-A16	Pin	2	49	037423-A49	Ratchet Lock Pin	2
17	037423-A17	Pin	1	50	037423-A50	Ratchet Pawl	2
18	033421-A03	O-Ring	2	51	037423-A51	Wave Washer	1
20	037423-A20	Pin	1	52	037423-A52	Thrust Washer	1
23	037423-A23	Bearing	1	53	037423-A53	Retaining Ring	1
24	037423-A24	Bearing	1	54	037423-A54	Ratchet Housing Assembly (incl. 37 (2))	1
25	037423-A25	End Cap	1	55	037423-A55	Bearing	2
26	037423-A26	End Plate	1	56	037423-A56	Bushing	1
27	037423-A27	Cylinder	1	57	037423-A57	Spacer	1
28	037423-A28	End Plate	1	58	037423-A58	Bearing	1
29	037423-A29	Rotor	1	59	037423-A59	Planet Gear	3
30	037423-A30	Rotor Blade	4	60	037423-A60	Work Spindle	1
31	037423-A31	Cylinder Dowel	1	62	037423-A62	Throttle Valve Assembly	1
32	037423-A32	Washer	1	TK-01	037323-ATK1	Ratchet Anvil Assembly (incl. 37.42.44 (2) .45.48 (2) .49 (2) .50 (2))	1
33	037423-A33	Inner Gear	1	TK	037423-ATK	Tune-Up Kit (incl. 8.9.10.15.18 (2))	1

★ Must be purchased in assembly set

● Recommended not to be purchased alone due to assembly difficulty

20131206R3

Air Pressure : 6.2 Bar (90 PSI)

Inspec. Item No.	Square drive		Std. Bolt Size		Free Speed R.P.M	MAX. Torque		Overall Length		Air Inlet BSPT/NPT	Air Hose ID	Avg. Air Consumption		Net Weight		Pressure Level A-weighted	Sound Power Level A-weighted	Sound Pressure Valve Peak C-weighted	Vib. M/S2
	inch	mm	inch	mm		inch	mm	cfm	l/min			lbs	kgs						
37323-080	3/8	3/8	M10	280	80	108	11	279	1/4" BSPT	3/8	4.0	113	2.76	1.25	94.00	105.00	96.00	2.52	
37323-081	3/8	3/8	M10	280	80	108	11	279	1/4" NPT	3/8	4.0	113	2.76	1.25	94.00	105.00	96.00	2.52	

http : //www.kingtony.com 8937323080-KT 192x288mm



KING TONY TOOLS CO., LTD.
No. 11, Alley 150, Lane 516, Sec. 2, Hsi Nan Rd.,
Wu-Jih Dist., Taichung City, Taiwan
Tel : 886-4-2335-3567 Fax : 886-4-2335-3642

**EC DECLARATION OF CONFORMITY
FOR NON-ANNEX IV MACHINERY
IN ACCORDANCE WITH
MACHINERY SAFETY DIRECTIVES
2006 / 42 / EC**

IMPACT WRENCH OPERATOR'S INSTRUCTION

This impact wrench has the CE approval

WE, **KING TONY TOOLS CO., LTD.** HEREBY CERTIFY THAT THE MACHINERY DESCRIBED BELOW CONFORMS WITH THE ESSENTIAL HEALTH AND SAFETY REQUIREMENTS OF MACHINERY SAFETY DIRECTIVES 2006/42/EC ON THE APPROXIMATION OF THE LAWS OF THE MEMBER STATES RELATING TO THE SAFETY OF MACHINERY,

IMPACT WRENCH

37323-080

AND COMPLY WITH THE PROVISIONS SET OUT IN THE FOLLOWING EUROPEAN STANDARD:

ISO 12100:2010 (RISK ASSESSMENT & RISK REDUCTION)

ISO 11148-6:2012 (SAFETY REQUIREMENTS)

ISO 15744:2002 (NOISE LEVEL)

ISO 28927-2:2009 (VIBRATION LEVEL)

DATE OF ISSUE: 7th January 2014

NAME: Lin Hsien-Wen

POSITION/TITLE: General manager

SIGNATURE: *Lin Hsien-Wen*



3/8" DR. RATCHET WRENCH



NO.37323-080
37323-081

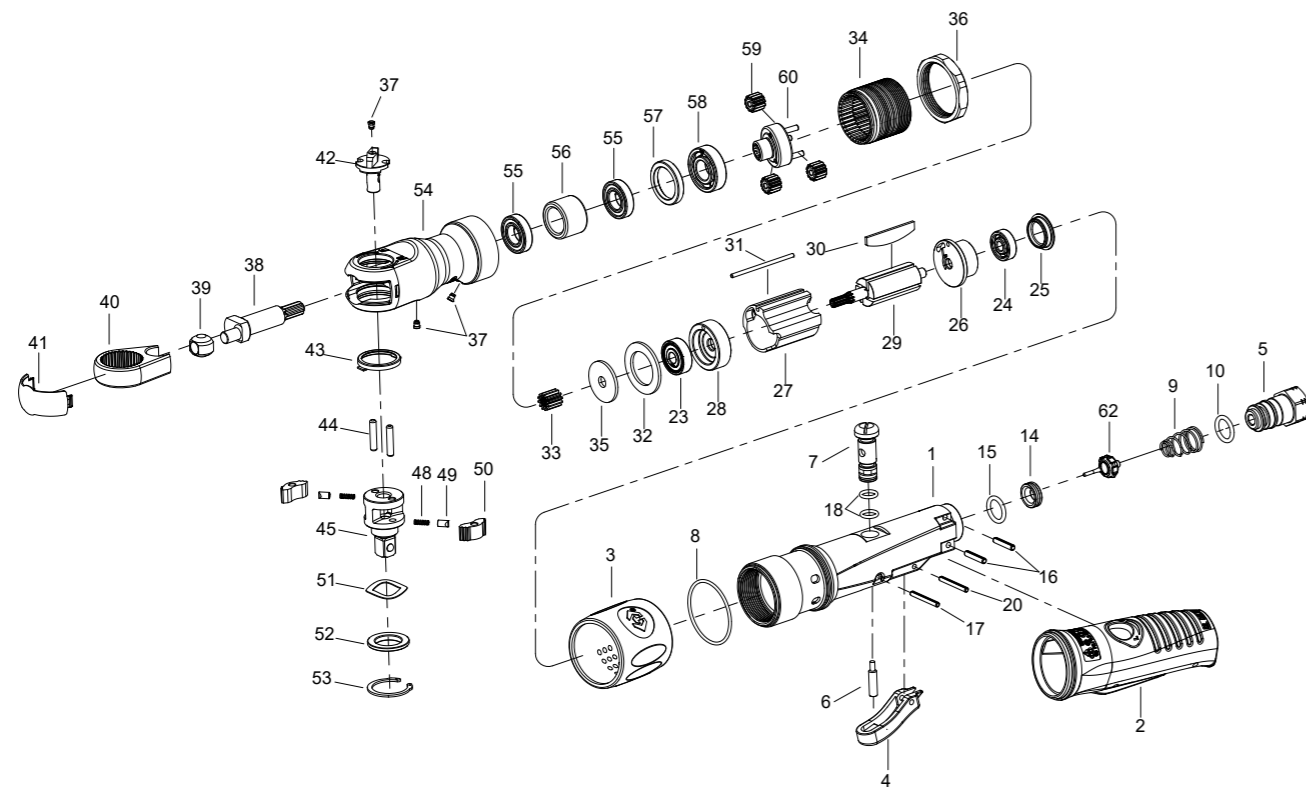

INDEX NO.	KT No.	DESCRIPTION	REQ'D NO.	INDEX NO.	KT No.	DESCRIPTION	REQ'D NO.
1	037423-A01	Motor Housing	1	34	037423-A34	Ring Gear	1
2	037423-A02	Rubber Grip	1	35	037423-A35	Spacer	1
3	037423-A03	Exhaust Deflector	1	36	037423-A36	Coupling Nut	1
4	037423-A04	Trigger	1	37	037221-A52	Grease Fitting	3
5	037423-A05	Air Inlet (for 19 BSPT)	1	38	037423-A38	Crank shaft	1
5A	037423-A05A	Air Inlet (for 18 NPT)	1	39	037423-A39	Drive Bushing	1
6	037423-A06	Throttle Valve Plunger	1	40	037423-A40	Ratchet Yoke	1
7	037423-A07	Air Regulator	1	41	037423-A41	Ratchet Housing Cover	1
8	037423-A08	O-Ring	1	42	037423-A42	Reverse Knob Assembly (incl. 37)	1
9	033812-A05	Spring	1	43	037423-A43	Thrust Washer	1
10	037423-A10	O-Ring	1	44	033421-A09	Pin	2
14	033411-A02	Throttle Valve Seat	1	45	037323-A45	Ratchet Anvil Assembly	1
15	033411-A20A	O-Ring	1	48	037423-A48	Ratchet Spring	2
16	037423-A16	Pin	2	49	037423-A49	Ratchet Lock Pin	2
17	037423-A17	Pin	1	50	037423-A50	Ratchet Pawl	2
18	033421-A03	O-Ring	2	51	037423-A51	Wave Washer	1
20	037423-A20	Pin	1	52	037423-A52	Thrust Washer	1
23	037423-A23	Bearing	1	53	037423-A53	Retaining Ring	1
24	037423-A24	Bearing	1	54	037423-A54	Ratchet Housing Assembly (incl. 37 (2))	1
25	037423-A25	End Cap	1	55	037423-A55	Bearing	2
26	037423-A26	End Plate	1	56	037423-A56	Bushing	1
27	037423-A27	Cylinder	1	57	037423-A57	Spacer	1
28	037423-A28	End Plate	1	58	037423-A58	Bearing	1
29	037423-A29	Rotor	1	59	037423-A59	Planet Gear	3
30	037423-A30	Rotor Blade	4	60	037423-A60	Work Spindle	1
31	037423-A31	Cylinder Dowel	1	62	037423-A62	Throttle Valve Assembly	1
32	037423-A32	Washer	1	TK-01	037323-ATK1	Ratchet Anvil Assembly (incl. 37.42.44 (2) .45.48 (2) .49 (2) .50 (2))	
33	037423-A33	Inner Gear	1	TK	037423-ATK	Tune-Up Kit (incl. 8.9.10.15.18 (2))	

★ Must be purchased in assembly set

● Recommended not to be purchased alone due to assembly difficulty

20131206R3

Air Pressure : 6.2 Bar (90 PSI)

Inspec. Item No.	Square drive		Std. Bolt Size		Free Speed		MAX. Torque		Overall Length		Air Inlet	Air Hose	Avg. Air Consumption		Net Weight		Pressure Level A-weighted	Sound Power Level A-weighted	Sound Pressure Valve Peak C-weighted	Vib. M/S2
	inch	mm	inch	mm	R.P.M	ft-lb	N.m	inch	mm	BSPT/NPT	ID	cfm	l/min	lbs	kgs	dB(A)	dB(A)	dB(C)		
37323-080	3/8	M10	280	80	108	11	279	1/4" BSPT	3/8	4.0	113	2.76	1.25	94.00	105.00	96.00	2.52			
37323-081	3/8	M10	280	80	108	11	279	1/4" NPT	3/8	4.0	113	2.76	1.25	94.00	105.00	96.00	2.52			

http : //www.kingtony.com 8937323080-KT 192x288mm



KING TONY TOOLS CO., LTD.
No. 11, Alley 150, Lane 516, Sec. 2, Hsi Nan Rd.,
Wu-Jih Dist., Taichung City, Taiwan
Tel : 886-4-2335-3567 Fax : 886-4-2335-3642

**EC DECLARATION OF CONFORMITY
FOR NON-ANNEX IV MACHINERY
IN ACCORDANCE WITH
MACHINERY SAFETY DIRECTIVES
2006 / 42 / EC**

IMPACT WRENCH OPERATOR'S INSTRUCTION

This impact wrench has the CE approval

WE, **KING TONY TOOLS CO., LTD.** HEREBY CERTIFY THAT THE MACHINERY DESCRIBED BELOW CONFORMS WITH THE ESSENTIAL HEALTH AND SAFETY REQUIREMENTS OF MACHINERY SAFETY DIRECTIVES 2006/42/EC ON THE APPROXIMATION OF THE LAWS OF THE MEMBER STATES RELATING TO THE SAFETY OF MACHINERY,

IMPACT WRENCH

37323-081

AND COMPLY WITH THE PROVISIONS SET OUT IN THE FOLLOWING EUROPEAN STANDARD:

ISO 12100:2010 (RISK ASSESSMENT & RISK REDUCTION)

ISO 11148-6:2012 (SAFETY REQUIREMENTS)

ISO 15744:2002 (NOISE LEVEL)

ISO 28927-2:2009 (VIBRATION LEVEL)



DATE OF ISSUE: 7th January 2014

NAME: Lin Hsien-Wen

POSITION/TITLE: General manager

SIGNATURE: *Lin Hsien-Wen*