

1-1/2" DR. IMPACT WRENCH

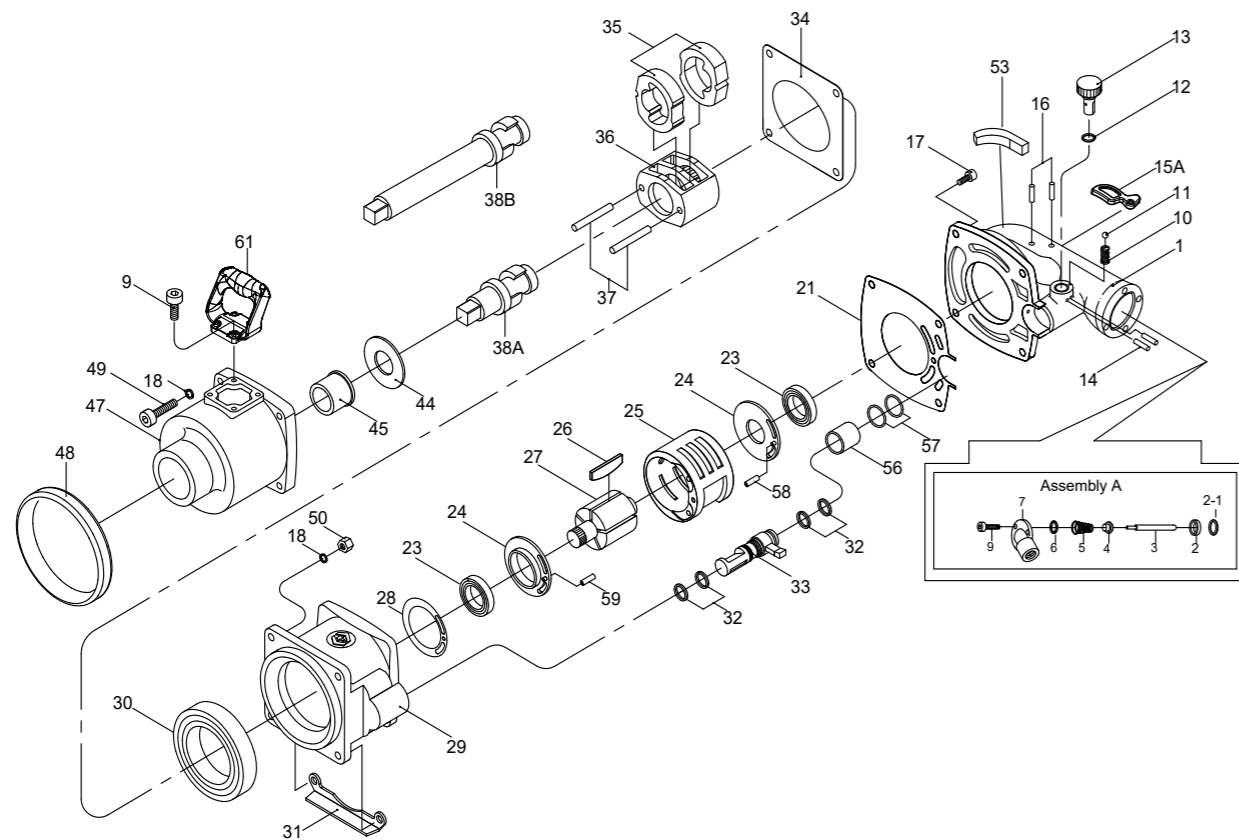

NO.33911-250
33912-250



INDEX NO.	KT No.	DESCRIPTION	REQ'D NO.	INDEX NO.	KT No.	DESCRIPTION	REQ'D NO.
★ 1	033851-B01	Backhead Assembly	1	30	033851-B30	Bearing	1
● 2	033812-A02A	Throttle Valve Seat	1	31	033851-B31	Motor Housing Protector	1
● 2-1	033851-B02A	Throttle Valve Gasket	1	32	033841-A09	O-Ring	4
● 3	033851-B03	Throttle Valve Plunger	1	33	033851-B33	Reverse Valve	1
● 4	033812-A04	Throttle Valve	1	34	033851-B34	Hammer Case Gasket	1
● 5	033851-B05	Throttle Valve Spring	1	35	033851-B35	Hammer	2
● 6	033841-A09	O-Ring	1	36	033851-B36	Hammer Frame	1
★ 7	033851-B07	Air Inlet Assembly (incl. 2.2-1.3.4.5.6.9)	1	37	033851-B37	Hammer Pin	2
9	033621-B04	Screw Assembly	8	38A	033911-A38A	Standard Anvil (for 33911-250)	1
10	033411-A14	Spring	1	38B	033911-A38B	8" Extended Anvil (for 33912-250)	1
11	033411-A13	Steel Ball	1	44	033911-A44	Washer	1
12	033851-B12	O-Ring	1	45	033911-A45	Bushing	1
13	033851-B13	Air Regulator	1	47	033911-A47	Hammer Case	1
14	033851-B14	Pin	2	48	033851-B48	Shield Housing Nose	1
15A	033851-B15A	Trigger	1	49	033851-B49	Screw	4
16	033812-A12	Pin	2	50	033812-A61	Lock Nut	4
17	033812-A21A	Screw Assembly	4	53	033851-B53	Rubber Cap	1
18	033812-A44A	Washer	6	56	033851-B56	Bushing	1
21	033851-B21	Gasket	1	57	033851-B57	O-Ring	2
● 23	033851-B23	Bearing	2	58	033812-A29A	Pin	1
★ 24	033851-B24	End Plate Assembly (incl. 23)	2	59	033812-A29	Pin	1
25	033851-B25	Cylinder	1	61	033812-A45	Side Spade Handle	1
26	033851-B26	Rotor Blade	7	TK-01	033851-BTK1	End Plate Assembly (incl. 23,24,58)	
27	033851-B27	Rotor	1	TK-02	033851-BTK2	End Plate Assembly (incl. 23,24,59)	
28	033851-B28	Gasket	1	TK-03	033911-ATK3	Hammer Case Assembly (incl. 45,47)	
29	033851-B29	Housing Assembly	1	TK	033851-BTK	Tune-Up Kit (incl. 5.6.10.11.12.21.26 (7) .28.32 (4) .34.57 (2))	

★ Must be purchased in assembly set

● Recommended not to be purchased alone due to assembly difficulty

Air Pressure : 6.2 Bar (90 PSI)

Inspec. Item No.	Square drive		Std. Bolt Size	Free Speed	MAX. Torque		Overall Length		Air Inlet	Air Hose ID	Avg. Air Consumption		Net Weight		Sound Pressure Level A-weighted	Sound Power Level A-weighted	Sound Pressure Peak C-weighted	Vib. M/S ²
	inch	mm			R.P.M	ft-lb	N.m	inch			mm	BSPT/NPT	cfm	l/min				
33911-250	1-1/2	1-25/32	M45	3000	2500	3388	17-53/64	453	1/2" BSPT	3/4	14.5	411	34.83	15.80	104.13	115.12	104.00	6.32
33912-250	1-1/2	1-25/32	M45	3000	2500	3388	23-53/64	605	1/2" BSPT	3/4	14.5	411	41.23	18.70	103.90	114.90	104.00	6.53

http : //www.kingtony.com 8933911250-KT 192x288mm



KING TONY TOOLS CO., LTD.
No. 11, Alley 150, Lane 516, Sec. 2, Hsi Nan Rd.,
Wu-Jih Dist., Taichung City, Taiwan
Tel : 886-4-2335-3567 Fax : 886-4-2335-3642

**EC DECLARATION OF CONFORMITY
FOR NON-ANNEX IV MACHINERY
IN ACCORDANCE WITH
MACHINERY SAFETY DIRECTIVES
2006 / 42 / EC**

**IMPACT WRENCH
OPERATOR'S INSTRUCTION**

This impact wrench has the CE approval

WE, **KING TONY TOOLS CO., LTD.** HEREBY CERTIFY THAT THE MACHINERY DESCRIBED BELOW CONFORMS WITH THE ESSENTIAL HEALTH AND SAFETY REQUIREMENTS OF MACHINERY SAFETY DIRECTIVES 2006/42/EC ON THE APPROXIMATION OF THE LAWS OF THE MEMBER STATES RELATING TO THE SAFETY OF MACHINERY,

IMPACT WRENCH

33912-250

AND COMPLY WITH THE PROVISIONS SET OUT IN THE FOLLOWING EUROPEAN STANDARD:

ISO 12100:2010 (RISK ASSESSMENT & RISK REDUCTION)

ISO 11148-6:2012 (SAFETY REQUIREMENTS)

ISO 15744:2002 (NOISE LEVEL)

ISO 28927-2:2009 (VIBRATION LEVEL)



DATE OF ISSUE: 7th January 2014

NAME: Lin Hsien-Wen

POSITION/TITLE: General manager

SIGNATURE: *Lin Hsien-Wen*

1-1/2" DR. IMPACT WRENCH



NO.33921-300
33922-300

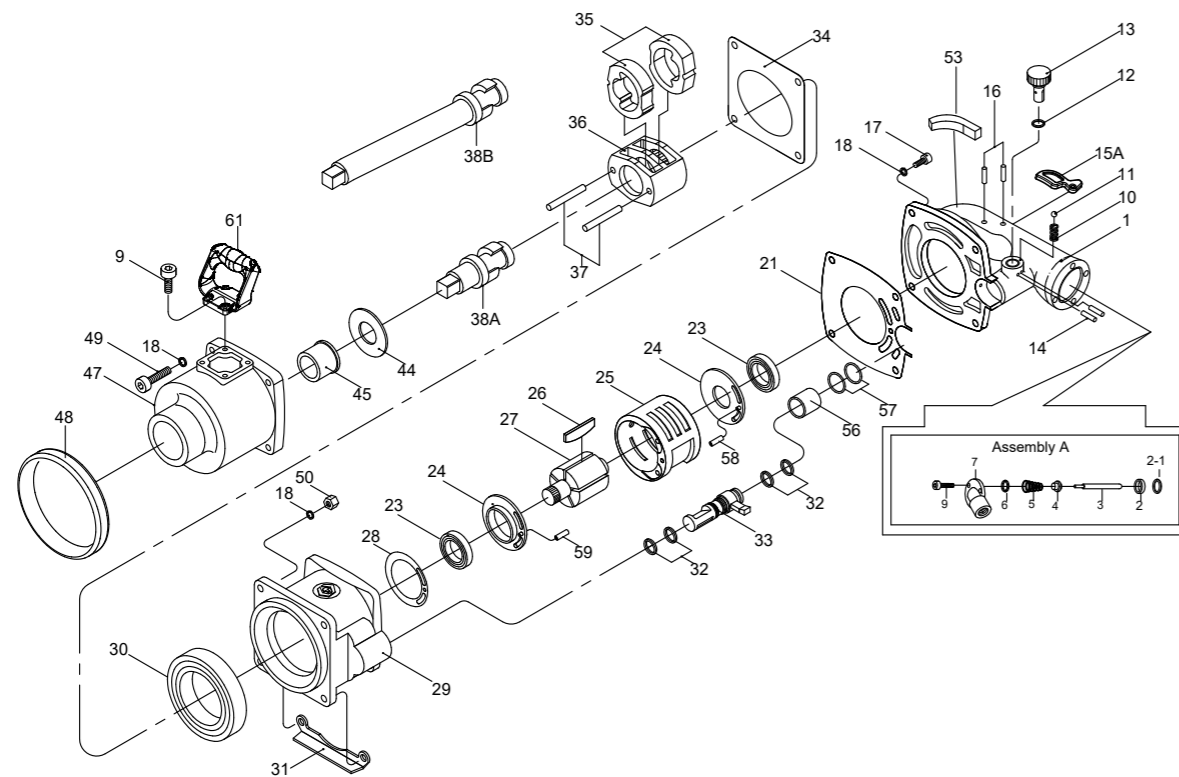

INDEX NO.	KT No.	DESCRIPTION	REQ'D NO.	INDEX NO.	KT No.	DESCRIPTION	REQ'D NO.
★ 1	033851-B01	Backhead Assembly	1	30	033851-B30	Bearing	1
• 2	033812-A02A	Throttle Valve Seat	1	31	033851-B31	Motor Housing Protector	1
• 2-1	033851-B02A	Throttle Valve Gasket	1	32	033841-A09	O-Ring	4
• 3	033851-B03	Throttle Valve Plunger	1	33	033921-A33	Reverse Valve	1
• 4	033812-A04	Throttle Valve	1	34	033851-B34	Hammer Case Gasket	1
• 5	033851-B05	Throttle Valve Spring	1	35	033851-B35	Hammer	2
• 6	033841-A09	O-Ring	1	36	033851-B36	Hammer Frame	1
★ 7	033851-B07	Air Inlet Assembly (incl. 2.2-1.3.4.5.6.8.9)	1	37	033851-B37	Hammer Pin	2
9	033621-B04	Screw Assembly	8	38A	033911-A38A	Standard Anvil (for 33921-300)	1
10	033411-A14	Spring	1	38B	033911-A38B	8" Extended Anvil (for 33922-300)	1
11	033411-A13	Steel Ball	1	44	033911-A44	Washer	1
12	033851-B12	O-Ring	1	45	033911-A45	Bushing	1
13	033851-B13	Air Regulator	1	47	033911-A47	Hammer Case	1
14	033851-B14	Pin	2	48	033851-B48	Shield Housing Nose	1
15A	033851-B15A	Trigger	1	49	033851-B49	Screw	4
16	033812-A12	Pin	2	50	033812-A61	Lock Nut	4
17	033921-A17	Screw	4	53	033851-B53	Rubber Cap	1
18	033812-A44A	Washer	10	56	033851-B56	Bushing	1
21	033921-A21	Gasket	1	57	033851-B57	O-Ring	2
• 23	033851-B23	Bearing	2	58	033812-A29A	Pin	1
★ 24	033851-B24	End Plate Assembly (incl. 23)	2	59	033812-A29	Pin	1
25	033921-A25	Cylinder	1	61	033812-A45	Side Spade Handle	1
26	033921-A26	Rotor Blade	7	TK-01	033851-BTK1	End Plate Assembly (incl. 23.24.58)	
27	033921-A27	Rotor	1	TK-02	033851-BTK2	End Plate Assembly (incl. 23.24.59)	
28	033851-B28	Gasket	1	TK-03	033911-ATK3	Hammer Case Assembly (incl. 45.47)	
29	033921-A29	Housing Assembly	1	TK	033921-ATK	Tune-Up Kit (incl. 5.6.10.11.12.21.26 (7) .28.32 (4) .34.57 (2))	

★ Must be purchased in assembly set
• Recommended not to be purchased alone due to assembly difficulty

Air Pressure : 6.2 Bar (90 PSI)

Inspec. Item No.	Square drive		Std. Bolt Size		Free Speed		MAX. Torque		Overall Length		Air Inlet	Air Hose	Avg. Air Consumption		Net Weight		Sound Pressure Level A-weighted	Sound Power Level A-weighted	Sound Pressure Valve Peak C-weighted	Vib. M/S2
	inch	mm	inch	mm	R.P.M	ft-lb	N.m	inch	mm	BSPT/NPT	ID	cfm	l/min	lbs	kgs	dB(A)	dB(A)	dB(C)	mm/s	
33921-300	1-1/2	2	M50	3000	3000	4065	17-3/4	451	1/2" BSPT	3/4	16.0	453	43.43	19.70	104.52	115.51	105.00	8.86		
33922-300	1-1/2	2	M50	3000	3000	4065	25-15/32	647	1/2" BSPT	3/4	16.0	453	50.27	22.80	104.52	115.61	105.00	7.12		

http : //www.kingtony.com 8933921300-KT 192x288mm



KING TONY TOOLS CO., LTD.
No. 11, Alley 150, Lane 516, Sec. 2, Hsi Nan Rd.,
Wu-Jih Dist., Taichung City, Taiwan
Tel : 886-4-2335-3567 Fax : 886-4-2335-3642

**EC DECLARATION OF CONFORMITY
FOR NON-ANNEX IV MACHINERY
IN ACCORDANCE WITH
MACHINERY SAFETY DIRECTIVES
2006 / 42 / EC**

**IMPACT WRENCH
OPERATOR'S INSTRUCTION**
This impact wrench has the CE approval

WE, **KING TONY TOOLS CO., LTD.** HEREBY CERTIFY THAT THE MACHINERY DESCRIBED BELOW CONFORMS WITH THE ESSENTIAL HEALTH AND SAFETY REQUIREMENTS OF MACHINERY SAFETY DIRECTIVES 2006/42/EC ON THE APPROXIMATION OF THE LAWS OF THE MEMBER STATES RELATING TO THE SAFETY OF MACHINERY,

IMPACT WRENCH

33922-300

AND COMPLY WITH THE PROVISIONS SET OUT IN THE FOLLOWING EUROPEAN STANDARD:
ISO 12100:2010 (RISK ASSESSMENT & RISK REDUCTION)
ISO 11148-6:2012 (SAFETY REQUIREMENTS)
ISO 15744:2002 (NOISE LEVEL)
ISO 28927-2:2009 (VIBRATION LEVEL)



DATE OF ISSUE: 7th January 2014

NAME: Lin Hsien-Wen

POSITION/TITLE: General manager

SIGNATURE: *Lin Hsien-Wen*