

1" DR. IMPACT WRENCH

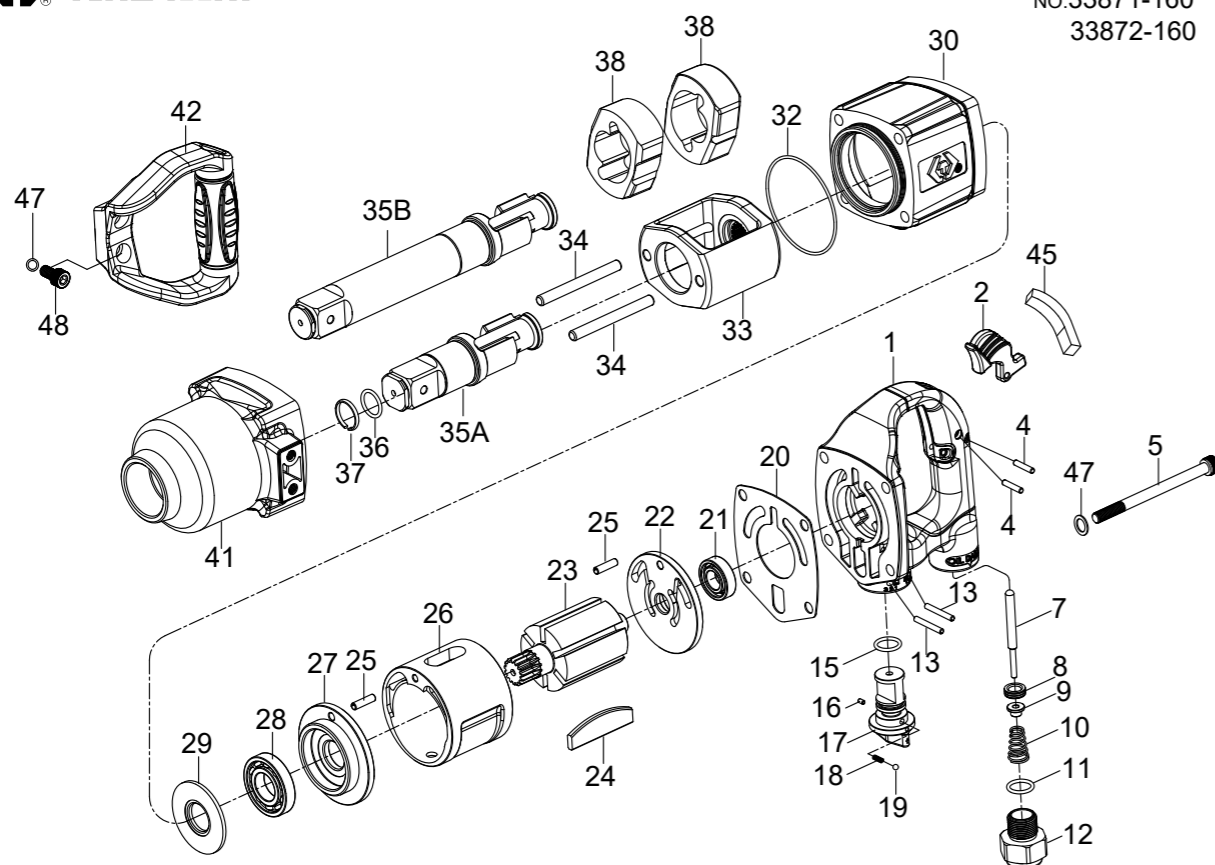

NO.33871-160
33872-160



INDEX NO.	KT No.	DESCRIPTION	REQ'D NO.	INDEX NO.	KT No.	DESCRIPTION	REQ'D NO.
★ 1	033671-A01	Backhead Assembly (incl. 8)	1	27	033671-A27	End Plate	1
2	033861-A02	Trigger	1	28	033631-C27	Bearing	1
4	033421-A09	Pin	2	29	033631-C35	Washer	1
5	033861-A05	Screw	4	30	033671-A30	Housing	1
7	033861-A07	Throttle Valve Plunger	1	32	033671-A32	O-Ring	1
● 8	033812-A02A	Throttle Valve Seat	1	33	033871-A33	Hammer Frame	1
9	033812-A04	Throttle Valve	1	34	033671-A34	Hammer Pin	2
10	033812-A05	Spring	1	35A	033871-A35A	Standard Anvil (for 33871-160)	1
11	033812-A06	O-Ring	1	35B	033871-A35B	6" Extended Anvil (for 33872-160)	1
12	033812-A10B	Air Inlet	1	36	033812-A48	O-Ring	1
13	033812-A14	Pin	2	37	033812-A49	Socket Retainer	1
15	033812-A06	O-Ring	1	38	033671-A38	Hammer	2
16	033812-A20	Pin	1	41	033871-A41	Hammer Case Assembly	1
17	033812-A17	Reverse Valve	1	42	033861-A42	Side Spade Handle	1
18	033411-A14	Spring	1	45	033861-A45	Rubber Cap	1
19	033812-A18	Steel Ball	1	47	033812-A44A	Washer	6
20	033671-A20	Gasket	1	48	033861-A48	Screw	2
● 21	033411-B24	Bearing	1	TK-01	033671-ATK1	End Plate Assembly (incl. 22.25)	
★ 22	033671-A22	End Plate Assembly (incl. 21)	1	TK-02	033671-ATK2	End Plate Assembly (incl. 25.27.28)	
23	033671-A23	Rotor	1	TK-03	033871-ATK3	Standard Anvil Assembly (incl. 35A.36.37)	
24	033671-A24	Rotor Blade	6	TK-04	033871-ATK4	6" Extended Anvil Assembly (incl. 35B.36.37)	
25	033861-A25	Pin	2				
26	033671-A26	Cylinder	1	TK	033871-ATK	Tune-Up Kit (incl. 10.11.15.18.19.20.24 (6) .32.36.37)	

- ★ Must be purchased in assembly set
- Recommended not to be purchased alone due to assembly difficulty

20140124R2

Inspec. Item No.	Square drive		Std. Bolt Size		Free Speed		MAX. Torque		Overall Length		Air Inlet		Air Hose		Avg. Air Consumption		Net Weight		Sound Pressure Level A-weighted	Sound Power Level A-weighted	Sound Pressure Valve Peak C-weighted	Vib. M/MS2
	inch	mm	inch	mm	R.P.M.	ft-lb	N.m	inch	mm	BSP/NPT	ID	cfm	l/min	lbs	kgs							
33871-160	1	1-3/16	M30	5500	1600	2170	12-45/64	323	1/2" BSPT	3/4	8.5	241	12.79	5.80	106.00	117.00	121.00	13.70				
33872-160	1	1-3/16	M30	5500	1600	2170	18-39/64	473	1/2" BSPT	3/4	8.5	241	14.77	6.70	104.00	115.00	119.00	14.98				

http : //www.kingtony.com 8933871160-KT 192x288mm



KING TONY TOOLS CO., LTD.
No. 11, Alley 150, Lane 516, Sec. 2, Hsi Nan Rd.,
Wu-Jih Dist., Taichung City, Taiwan
Tel : 886-4-2335-3567 Fax : 886-4-2335-3642

**EC DECLARATION OF CONFORMITY
FOR NON-ANNEX IV MACHINERY
IN ACCORDANCE WITH
MACHINERY SAFETY DIRECTIVES**

2006 / 42 / EC

IMPACT WRENCH OPERATOR'S INSTRUCTION

This impact wrench has the CE approval

WE, **KING TONY TOOLS CO., LTD.** HEREBY CERTIFY THAT THE MACHINERY DESCRIBED BELOW CONFORMS WITH THE ESSENTIAL HEALTH AND SAFETY REQUIREMENTS OF MACHINERY SAFETY DIRECTIVES 2006/42/EC ON THE APPROXIMATION OF THE LAWS OF THE MEMBER STATES RELATING TO THE SAFETY OF MACHINERY,

IMPACT WRENCH

33871-160

AND COMPLY WITH THE PROVISIONS SET OUT IN THE FOLLOWING EUROPEAN STANDARD:

ISO 12100:2010 (RISK ASSESSMENT & RISK REDUCTION)

ISO 11148-6:2012 (SAFETY REQUIREMENTS)

ISO 15744:2002 (NOISE LEVEL)

ISO 28927-2:2009 (VIBRATION LEVEL)

DATE OF ISSUE: 7th January 2014

NAME: Lin Hsien-Wen

POSITION/TITLE: General manager

SIGNATURE: *Lin Hsien-Wen*

