

1" DR. IMPACT WRENCH

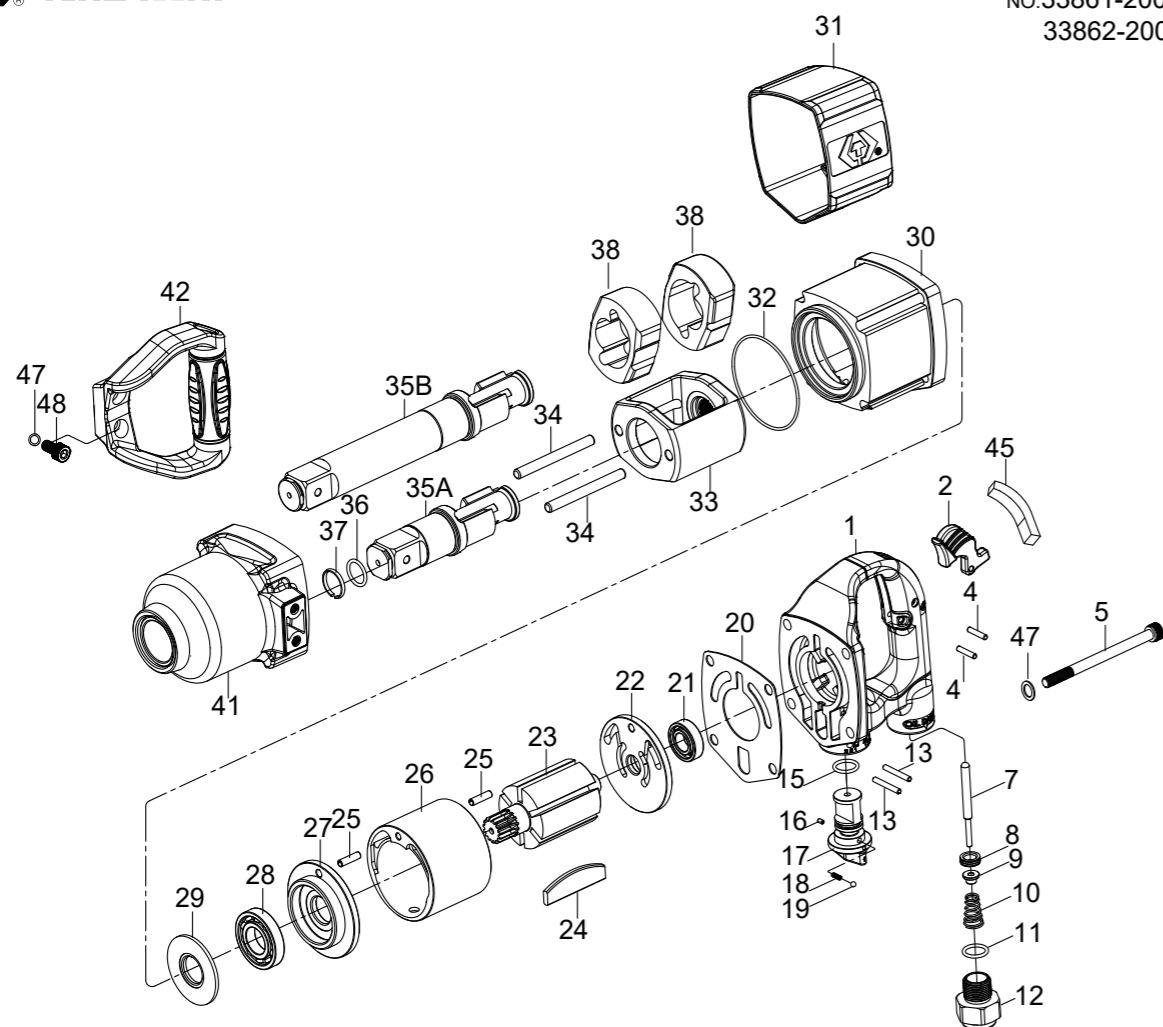

NO.33861-200
33862-200



INDEX NO.	KT No.	DESCRIPTION	REQ'D NO.	INDEX NO.	KT No.	DESCRIPTION	REQ'D NO.
1	033861-A01	Backhead Assembly	1	28	033631-C27	Bearing	1
2	033861-A02	Inside Trigger	1	29	033631-C35	Washer	1
4	033421-A09	Pin	2	30	033861-A30	Housing	1
5	033861-A05	Screw	4	31	033861-A31	Rubber Grip	1
7	033861-A07	Throttle Valve Plunger	1	32	033861-A32	O-Ring	1
8	033812-A02A	Throttle Valve Seat	1	33	033861-A33	Hammer Frame	1
9	033812-A04	Throttle Valve	1	34	033861-A34	Hammer Pin	2
10	033812-A05	Spring	1	35A	033861-A35A	Standard Anvil (for 33861-200)	1
11	033812-A06	O-Ring	1	35B	033861-A35B	6" Extended Anvil (for 33862-200)	1
12	033812-A10B	Air Inlet	1	36	033812-A48	O-Ring	1
13	033812-A14	Pin	2	37	033812-A49	Socket Retainer	1
15	033812-A06	O-Ring	1	38	033861-A38	Hammer	2
16	033812-A20	Pin	1	41	033861-A41	Hammer Case Assembly	1
17	033812-A17	Reverse Valve	1	42	033861-A42	Side Spade Handle	1
18	033411-A14	Spring	1	45	033861-A45	Rubber Cap	1
19	033812-A18	Steel Ball	1	47	033812-A44A	Washer	6
20	033861-A20	Gasket	1	48	033861-A48	Screw	2
21	033411-B24	Bearing	1	TK-01	033861-ATK1	End plate Assembly (incl. 21,22,25)	
22	033861-A22	End Plate (incl. 21)	1	TK-02	033861-ATK2	End plate Assembly (incl. 25,27,28)	
23	033861-A23	Rotor	1	TK-03	033861-ATK3	Standard Anvil (incl. 35A,36,37)	
24	033861-A24	Rotor Blade	6	TK-04	033861-ATK4	6" Extended Anvil (incl. 35B,36,37)	
25	033861-A25	Pin	2	TK-05	033861-ATK5	Side Spade Handle (incl. 42,47 (2),48 (2))	
26	033861-A26	Cylinder	1	TK	033861-ATK	Tune-Up Kit (incl. 10,11,15,18,19,20,24 (6) ,32,36,37)	
27	033861-A27	End Plate	1				

★ Must be purchased in assembly set

● Recommended not to be purchased alone due to assembly difficulty

20131206R3

Air Pressure : 6.2 Bar (90 PSI)

Inspec. Item No.	Square drive		Free Speed	MAX. Torque		Overall Length		Air Inlet	Air Hose	Avg. Air Consumption		Net Weight		Sound Pressure Level A-weighted	Sound Power Level	Sound Pressure Valve Peak C-weighted	Vib. M/S2	
	inch	mm		ft-lb	N.m	inch	mm			cfm	l/min	lbs	kgs					
33861-200	1	1-27/64	M36	5000	2000	2712	13-43/64	347	1/2" BSPT	3/4	9.0	255	16.31	7.40	106.00	121.00	117.00	17.20
33862-200	1	1-27/64	M36	5000	2000	2712	19-3/16	487	1/2" BSPT	3/4	9.0	255	17.86	8.10	104.00	120.00	115.00	14.50

http : //www.kingtony.com 8933861200-KT 192x288mm



KING TONY TOOLS CO., LTD.
No. 11, Alley 150, Lane 516, Sec. 2, Hsi Nan Rd.,
Wu-Jih Dist., Taichung City, Taiwan
Tel : 886-4-2335-3567 Fax : 886-4-2335-3642

**EC DECLARATION OF CONFORMITY
FOR NON-ANNEX IV MACHINERY
IN ACCORDANCE WITH
MACHINERY SAFETY DIRECTIVES**

2006 / 42 / EC

IMPACT WRENCH OPERATOR'S INSTRUCTION

This impact wrench has the CE approval

WE, **KING TONY TOOLS CO., LTD.** HEREBY CERTIFY THAT THE MACHINERY DESCRIBED BELOW CONFORMS WITH THE ESSENTIAL HEALTH AND SAFETY REQUIREMENTS OF MACHINERY SAFETY DIRECTIVES 2006/42/EC ON THE APPROXIMATION OF THE LAWS OF THE MEMBER STATES RELATING TO THE SAFETY OF MACHINERY,

IMPACT WRENCH

33861-200

AND COMPLY WITH THE PROVISIONS SET OUT IN THE FOLLOWING EUROPEAN STANDARD:

ISO 12100:2010 (RISK ASSESSMENT & RISK REDUCTION)

ISO 11148-6:2012 (SAFETY REQUIREMENTS)

ISO 15744:2002 (NOISE LEVEL)

ISO 28927-2:2009 (VIBRATION LEVEL)

DATE OF ISSUE: 7th January 2014

NAME: Lin Hsien-Wen

POSITION/TITLE: General manager

SIGNATURE: *Lin Hsien-Wen*

