

1" DR. IMPACT WRENCH

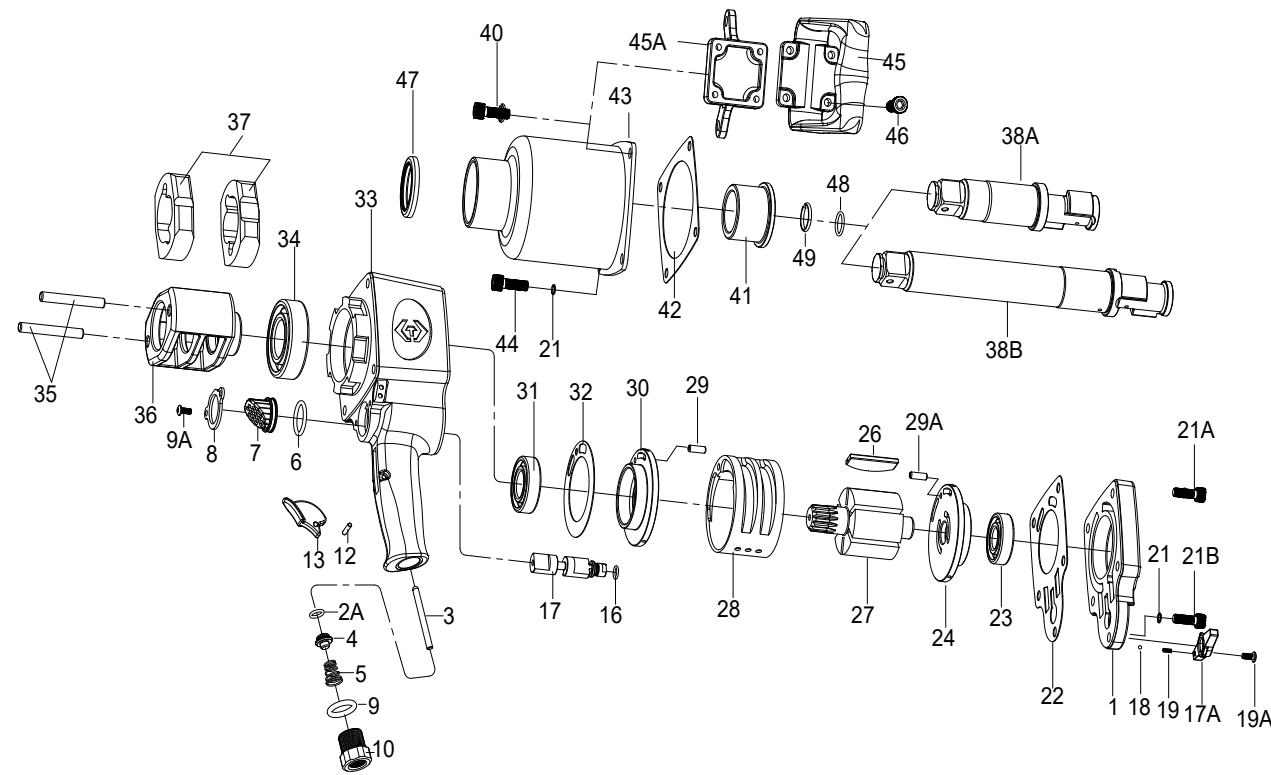

NO.33841-180
33842-180



INDEX NO.	KT No.	DESCRIPTION	REQ'D NO.	INDEX NO.	KT No.	DESCRIPTION	REQ'D NO.
1	033841-A01	Backhead	1	29A	033812-A29A	Pin	1
2A	033621-B21	O-Ring	1	★30	033812-A30	End Plate Assembly (incl. 31)	1
3	033841-A03	Throttle Valve Plunger	1	●31	033812-A31	Bearing	1
4	033841-A04	Throttle Valve	1	32	033812-A32	Gasket	1
5	033841-A05	Spring	1	★33	033841-A33	Housing Assembly	1
6	033841-A06	O-Ring	1	34	033832-C34	Bearing	1
7	033841-A07	Exhaust Deflector	1	35	033832-C35	Hammer Pin	2
8	033841-A08	Retainer	1	36	033832-C36	Hammer Frame	1
9	033841-A09	O-Ring	1	37	033832-C37	Hammer	2
9A	033621-B41	Screw	2	●38A	033832-C38A	Standard Anvil (for 33841-180)	1
10	033841-A10	Air Inlet	1	●38B	033832-C38B	6" Extended Anvil (for 33842-180)	1
12	033421-A09	Trigger Pin	1	40	033812-A21A	Screw Assembly	2
13	033841-A13	Trigger	1	41	033832-C41	Bushing	1
16	037221-A02	O-Ring	1	42	033832-C42	Hammer Case Gasket	1
17	033841-A17	Reverse Valve	1	43	033841-A43	Hammer Case	1
17A	033841-A17A	Reverse Valve Knob	1	44	033841-A21B	Screw Assembly	2
18	033812-A18	Steel Ball	1	45	033812-A45	Side Spade Handle	1
19	033841-A19	Spring	1	45A	033832-C51	Support Handle	1
19A	033841-A19A	Screw	1	46	033621-B04	Screw Assembly	4
●21	033812-A44A	Washer	3	47	033812-A47	Oil Seal	1
★21A	033812-A21A	Screw Assembly	4	48	033812-A48	O-Ring	1
★21B	033841-A21B	Screw Assembly (incl. 21)	1	49	033812-A49	Socket Retainer	1
22	033841-A22	Gasket	1	TK-01	033812-ATK1	End Plate Assembly (incl. 23,24,29A)	
●23	033812-A23	Bearing	1	TK-02	033812-ATK2	End Plate Assembly (incl. 29,30,31)	
★24	033812-A24	End Plate Assembly (incl. 23)	1	TK-03	033832-CTK3	Standard Anvil Assembly (incl. 38A,48,49)	
26	033812-A26	Rotor Blade	6	TK-04	033832-CTK4	6" Extended Anvil Assembly (incl. 38B,48,49)	
27	033812-A27	Rotor	1	TK-05	033841-ATK5	Hammer Case Assembly (incl. 41,43,47)	
28	033812-A28	Cylinder	1	TK	033841-ATK	Tune-Up Kit (incl. 2A,5,6,9,16,18,19,22,26 (6) ,32,42,48,49)	
29	033812-A29	Pin	1				

★ Must be purchased in assembly set

● Recommended not to be purchased alone due to assembly difficulty

20131206R4

Air Pressure : 6.2 Bar (90 PSI)

Inspec. Item No.	Square drive	Std. Bolt Size		Free Speed R.P.M	MAX. Torque		Overall Length		Air Inlet BSPT/NPT	Air Hose ID	Avg. Air Consumption		Net Weight		Sound Pressure Level A-weighted	Sound Power Level A-weighted	Sound Pressure Valve Peak C-weighted	Vib. M/S2
		inch	mm		ft-lb	N.m	inch	mm			cfm	l/min	lbs	kgs				
33841-180	1	1-27/64	M36	4000	1800	2440	12-3/32	307	1/2" BSPT	3/4	9.0	255	23.41	10.62	101.56	112.56	103.00	4.37
33842-180	1	1-27/64	M36	4000	1800	2440	20-5/64	510	1/2" BSPT	3/4	9.0	255	27.60	12.52	99.85	110.84	100.00	5.87

http : //www.kingtony.com 8933841180-KT 192x288mm



KING TONY TOOLS CO., LTD.
No. 11, Alley 150, Lane 516, Sec. 2, Hsi Nan Rd.,
Wu-Jih Dist., Taichung City, Taiwan
Tel : 886-4-2335-3567 Fax : 886-4-2335-3642

**EC DECLARATION OF CONFORMITY
FOR NON-ANNEX IV MACHINERY
IN ACCORDANCE WITH
MACHINERY SAFETY DIRECTIVES
2006 / 42 / EC**

IMPACT WRENCH OPERATOR'S INSTRUCTION

This impact wrench has the CE approval

WE, **KING TONY TOOLS CO., LTD.** HEREBY CERTIFY THAT THE MACHINERY DESCRIBED BELOW CONFORMS WITH THE ESSENTIAL HEALTH AND SAFETY REQUIREMENTS OF MACHINERY SAFETY DIRECTIVES 2006/42/EC ON THE APPROXIMATION OF THE LAWS OF THE MEMBER STATES RELATING TO THE SAFETY OF MACHINERY,

IMPACT WRENCH

33841-180

AND COMPLY WITH THE PROVISIONS SET OUT IN THE FOLLOWING EUROPEAN STANDARD:

ISO 12100:2010 (RISK ASSESSMENT & RISK REDUCTION)

ISO 11148-6:2012 (SAFETY REQUIREMENTS)

ISO 15744:2002 (NOISE LEVEL)

ISO 28927-2:2009 (VIBRATION LEVEL)

DATE OF ISSUE: 7th January 2014

NAME: Lin Hsien-Wen

POSITION/TITLE: General manager

SIGNATURE: *Lin Hsien-Wen*

