

NO.9TY145-008A-B

THE CONSTRUCTION OF TRANSMISSION JACK

Part	Description	Qty
1	Saddle	1
2	Ram	1
3	Cylinder	1
4	Hand Wheel	1
5	Foot Operated Pump	1
6	Wheel stand	1

Capacity: 0.8 Ton
Min. height :850mm
Max. height :1840mm

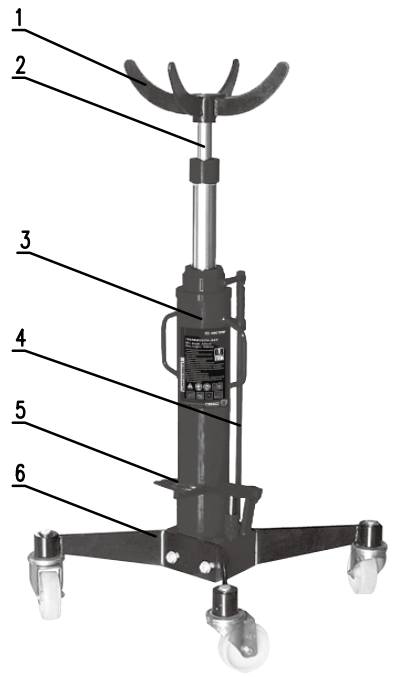

NO.9TY145-015A-B

THE CONSTRUCTION OF TRANSMISSION JACK

Part	Description	Qty
1	Saddle	1
2	Ram	1
3	Cylinder	1
4	Hand Wheel	1
5	Foot Operated Pump	1
6	Wheel stand	1

Capacity: 1.5 Ton
Min. height :1130mm
Max. height :1915mm

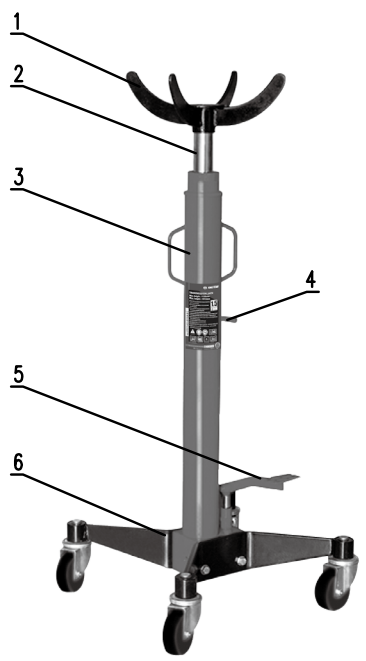



KING TONY

TRANSMISSION JACK OPERATION MANUAL



**0.4
TON**

No.9TY145-004A-B



**0.6
TON**

No.9TY145-006A-B



**0.8
TON**

No.9TY145-008A-B

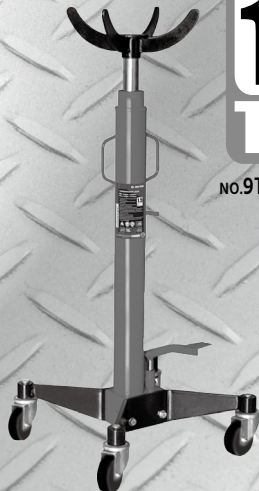

**1.5
TON**

No.9TY145-015A-B



NO.9TY145

Please wear proper safety gear while working.



SAFETY PRECAUTIONS

- The jack is designed for assembly / disassembly of automotive gearbox. Do not use for other purpose.
- The jack is designed for use on hard, flat surface that is able to withstand the current load. Using on sloping and very soft surface, can lead to damage the cargo or personal inquiry.
- Do not exceed the jack's rated capacity.
- Always rest the load on the central part of the jack saddle.
- Check before use, if load volume fit to the size of the jack saddle.
- Before starting work, make sure that the vehicle is raised at the proper, safe height, and that it is adequately protected against displaced.
- Before lifting or lowering the load, make sure that all person are at a safe distance.
- Before lifting or lowering the loads, make sure that it is firmly positioned on the jack saddle and it is not possible to slide up from the saddle.
- The load should be lowered very slowly, rapidly lowering may damage the hydraulic system and consequently, to the fall of the load and its damage.
- During work, the jack should be secured in such way that it can not move the jack with a raised object.
- Personnel associated with the use and maintenance of the equipment must be careful, skilled, knowledgeable, and trained, in the safe use of the equipment and its proper use.
- Before working with the jack, carefully evaluate its technical condition.
- Do not use the jack if you see any defect. Only fully functional jack ensures safe operation.
- Before each use, inspect the oil. To refill, use only new oil for hydraulic equipment. Do not use any brake fluids, motor oils, alcohol or other detergents.
- All the moving parts must always be well oiled.
- During the jack operation, the operator must constantly observe and make sure the device works properly.
- If jack tips or leans, stop what you are doing and moving quickly to a safe distance. Do not try to hold or steady jack.
- During transport this jack with or without load, make sure saddle must be maximum lowered. Pay attention to the objects which lie on the ground and can cause jack fall with load.
- Never work under or in close proximity to the load, which is supported only by a jack. Immediately secure the load on saddle and transport load to the final working place.

WARNING

The warnings, cautions and instructions discussed in this manual cannot cover all possible conditions and situations that may occur. It must be understood by the user that common sense and caution are attributes which cannot be built into the appliance, but must be supplied by the user.

- The operator working area must provide the ability to maintain a safe distance and exclude the slips and falls.
- Do not wear loose clothing, neckties or jewellery, they can be caught in moving parts. Use protective clothing and non-slip footwear when working. Wear protective hair covering to contain long hair.
- Keep work area clean and well lit. Cluttered and dark areas invite accidents.
- Observe working area. Do not use in wet or damp locations.
- Keep away from children. Children must never be allowed in the work area. Do not let them handle machines tools, or equipment.
- Tools must be stored in a dry location to inhibit rust. Keep it well protected and store it out of the reach of children and by standers .
- Check for damaged parts.

WARNING

- Replacement parts and accessories use only original replacement parts. If use of any other parts will void the warranty.
- Do not use tool while tired or under the influence of drugs, alcohol or medication.
- No alterations to the jack shall be made. Failure to heed this warning can result in injury or material property damage

INSTALLATION OF THE TRANSMISSION JACK

- Attach the two wheel stand by turning the screw according with clockwise direction.
- Attach the four wheels to the base of the jack by screwing the upper nut accordance with clockwise direction and the lower nut. blocked using the key.

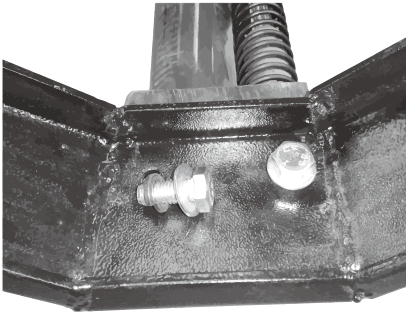

- Be sure to retain the wheels at right angles to wheelstand.
- To vent the jack, loosen the vent screw and than pump the foot operated pump (no.6 , Fig.1), in order to displace the air from hydraulic system. Once above is done, tighten the screw again.
- Check that the jack is working properly.

USAGE :

Before each use, carry out any inspection visually – check oil leaks, damage and worn parts.

LIFTED :

Lifting jack occurs through the use of foot operated pump (no.6 , Fig. 1).

MAINTENANCE

- When replenishing or replacing hydraulic fluid always use high quality hydraulic fluid. Never use brake fluid, alcohol, glycerine, detergents, motor oil, because the wrong fluid can cause serious internal damage to the jack.
- Jack must be cleaned regularly, so that it always remains in good condition and proper lubrication of moving parts.
- All moving parts must be always well oiled.
- Protect jack against the weather, corrosion, dirtiness and mechanical damage.
- Store and move only in upright position.
- According to the life cycle of jack, after 2 years of operation, the oil must be replaced for the new.

Responsibility of the owner and/or user

- Before using this jack the owner and/or user needs to refer to the warnings and instructions of the manufacturer's manual.
- People working with this jack must be careful, skilled, knowledgeable and trained with safe use of this equipment and its proper use in the service of motor vehicle and their components.

POSSIBLE REASON FOR PROBLEM & SOLUTION	Jack does not lift load	Jack does not keep load up	Jack does not lift to maximum lifting height	Jack does not come down to minimum lifting height	Pump appears to be 'soft' under weight	Oil leaks out around oil container plug
Not enough oil in oil container pour in some oil	●		●		●	
Too much oil in oil container pour out some oil						●
Too much air in hydraulic system: release air from hydraulic system	●		●	●	●	
Release valves not fully closed: make sure that release valve is not blocked in lowered position	●	●				

No.9TY145-004A-B

THE CONSTRUCTION OF TRANSMISSION JACK

Part	Description	Qty
1	Saddle	1
2	Ram	1
3	Cylinder	1
4	Hand Wheel	1
5	Foot Operated Pump	1
6	Wheel stand	1

Capacity: 0.4 Ton
Min. height :1240mm
Max. height :2105mm

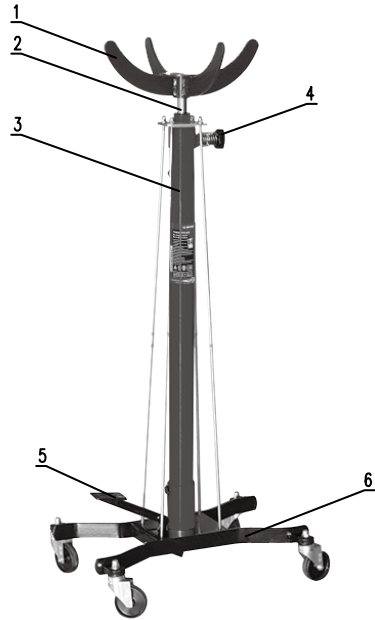

No.9TY145-006A-B

THE CONSTRUCTION OF TRANSMISSION JACK

Part	Description	Qty
1	Saddle	1
2	Ram	1
3	Cylinder	1
4	Hand Wheel	1
5	Foot Operated Pump	1
6	Wheel stand	1

Capacity: 0.6 Ton
Min. height :1135mm
Max. height :1980mm

