

- ENGINE TIMING LOCKING TOOL KIT – BMW
- KIT DE CALAGE MOTEUR – BMW
- KIT DE CALADO MOTOR – BMW
- MOTOR AFSTELSET – BMW
- Motoreinstell-Werkzeug für Dieselmotoren von BMW

no.9AT2107



- The kit includes camshaft alignment tool, flywheel locking tool, crankshaft pulley turning tool, and also high pressure pump sprocket removal tool.
- Suitable for BMW N47 / N47S / N57 2.0 and 3.0 twin camshaft diesel chain drive engine.
- Use to set & lock the camshaft and crankshaft when adjusting valve timing on engine correctly.
- The (F) new removal tool can remove the high pressure pump sprocket without dismantling the engine.

Diesel 2.0d/3.0d N47 / N47S / N57 Chain Drive

MODEL	1 Series	X Series
	116d/118d/120d/123d E81/82/87/88 (07-12)	X1 sDrive 18d/20d E84 (09-12) X1 xDrive 18d/20d/23d E84 (09-12)
3 Series	316d/318d/320d/325d/330d/330xd E90/91/92/93 (07-12)	X3 20d E83 (07-10) X3 xDrive 1.8d/30d E83 (08-12)
	5 Series	X5 30d/xDrive 40d E70 (10-12) X6 xDrive 30d/40d E71/72 (10-12)
7 Series	520d E60/61 (07-10) 525d/530d/535d F10/11 (10-12) 530d GT/535d GT F07 (09-12)	
	730d/730Ld/740d/740d xDrive F01/02/04 (08-12)	
ENGINE	N47 / N47S	N57
	D20A D20B D20T0 D2000 D20U0	D30U0 D3000 D3001 D30T0

CONTENTS:

- A - Camshaft Alignment Tool
- B - Flywheel Locking Tool
- C - Crankshaft Turning Tool
- D/F - High Pressure Pump Sprocket Removal Tool
- E - Tensioner Locking Pin

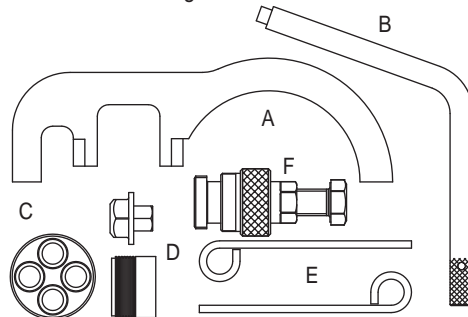

- Ce kit contient un outil d'alignement d'arbre à cames, un outil de verrouillage du volant moteur, un outil de rotation de vilebrequin ainsi qu'un outil d'extraction de pignon de pompe à haute pression.
- Compatible moteurs diesel à chaîne BMW N47 / N47S / N57 2.0 et 3.0 double arbre à cames.
- Utilisé pour la mise en place et le verrouillage de l'arbre à cames et du vilebrequin lors du calage moteur.
- Extracteur de pompe d'injection (F) permet de retirer le pignon de la pompe haute pression sans démonter le moteur.

Diesel 2.0d/3.0d N47 / N47S / N57 (Chaîne)

MODELE	Serie 1	Serie X
	116d/118d/120d/123d E81/82/87/88 (07-12)	X1 sDrive 18d/20d E84 (09-12) X1 xDrive 18d/20d/23d E84 (09-12)
3 Series	316d/318d/320d/325d/330d/330xd E90/91/92/93 (07-12)	X3 20d E83 (07-10) X3 xDrive 1.8d/30d E83 (08-12)
	5 Series	X5 30d/xDrive 40d E70 (10-12) X6 xDrive 30d/40d E71/72 (10-12)
7 Series	520d E60/61 (07-10) 525d/530d/535d F10/11 (10-12) 530d GT/535d GT F07 (09-12)	
	730d/730Ld/740d/740d xDrive F01/02/04 (08-12)	
MOTEUR	N47 / N47S	N57
	D20A D20B D20T0 D2000 D20U0	D30U0 D3000 D3001 D30T0

CONTIENT:

- A - outil de verrouillage du volant moteur
- B - outil d'alignement d'arbre à cames
- C - outil de rotation de vilebrequin
- D/F - outil d'extraction de pignon de pompe à haute pression
- E - Pige de maintient

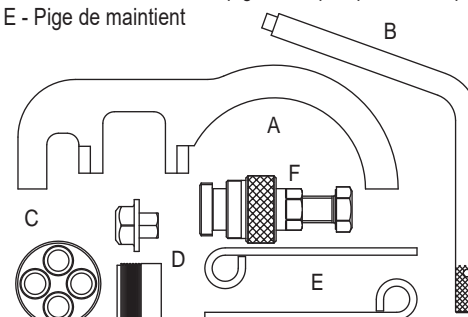

- Este kit contiene una herramienta de alineación de árbol de levas, una herramienta de cierre del volante motor, una herramienta de rotación de la polea de cigüeñal y una herramienta de extracción del piñón de bomba de alta presión.
- Compatible motores diesel de cadena BMW N47 / N47S / N57 2.0 y 3.0 doble árbol de levas.
- Útil para posicionar y bloquear el árbol de levas y el cigüeñal durante el calado del motor.
- Extractor de bomba de inyección (F) que permite sacar el piñón de la bomba de alta presión sin desmontar el motor.

Diesel 2.0d/3.0d N47 / N47S / N57 (Cadena)

MODELO	Serie 1	Serie X
	116d/118d/120d/123d E81/82/87/88 (07-12)	X1 sDrive 18d/20d E84 (09-12) X1 xDrive 18d/20d/23d E84 (09-12)
3 Series	316d/318d/320d/325d/330d/330xd E90/91/92/93 (07-12)	X3 20d E83 (07-10) X3 xDrive 1.8d/30d E83 (08-12)
	5 Series	X5 30d/xDrive 40d E70 (10-12) X6 xDrive 30d/40d E71/72 (10-12)
7 Series	520d E60/61 (07-10) 525d/530d/535d F10/11 (10-12) 530d GT/535d GT F07 (09-12)	
	730d/730Ld/740d/740d xDrive F01/02/04 (08-12)	
MOTOR	N47 / N47S	N57
	D20A D20B D20T0 D2000 D20U0	D30U0 D3000 D3001 D30T0

CONTIENE :

- A - Herramienta de cierre del volante motor
- B - Herramienta de alineación del árbol de levas
- C - Herramienta de rotación de la polea de cigüeñal
- D/F - Herramienta de extracción del piñón de bomba de alta presión
- E - Varilla de sujeción

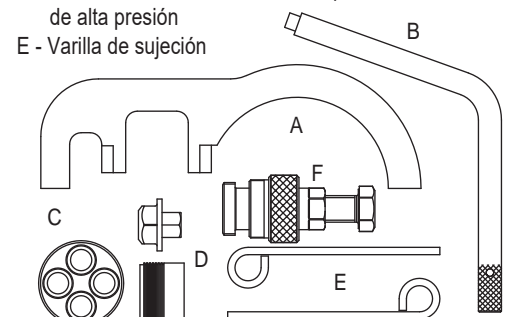

- Deze set bevat een nokkenas uitlijn gereedschap, een afstelgereedschap voor het vliegwiel, een rotatiegereedschap voor de krukspoelie en een trekgereedschap voor hogedruk injectiepomp.
- Geschikt voor dieselmotoren met ketting BMW N47 / N47S / N57 2.0 en 3.0 dubbele nokkenas.
- Gebruikt voor het monteren en het afstellen van de nokkenas en de krukas tijdens het afstellen van de motor.
- Trekker voor dieselin spuitpomp speciaal ontworpen om het tandwiel uit de hogedrukpomp te verwijderen zonder demontage van de motor.

- Dieses Kit beinhaltet ein Schwungscheiben-Blockierwerkzeug, Kurbelwellen-Fixierdorn, ein Nockenwellen-Fixierwerkzeug und einen Abzieher für die Einspritzpumpe.
- Geeignet für alle BMW N47 / N47S / N57 2.0 und 3.0 Dieselmotoren.
- Zum Arretieren bzw. Positionieren der Motorwellen wie Nockenwelle und Kurbelwelle beim Steuerkettenwechsel oder der Motorreparatur.
- Der Einspritzpumpenabzieher (F) entfernt das Ritzel aus der Hochdruckpumpe, ohne den Motor auseinander zu nehmen.

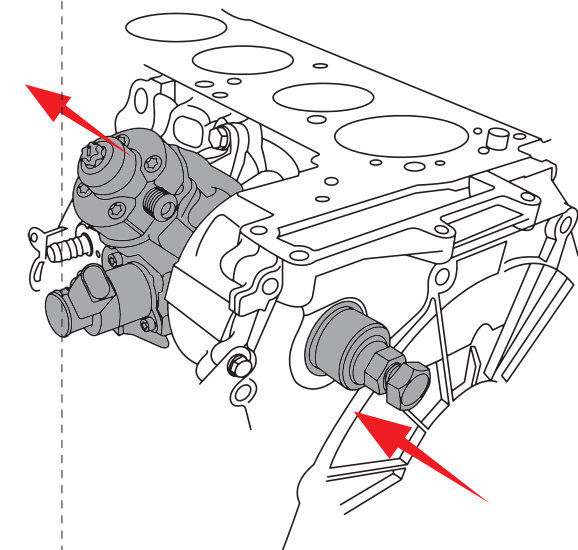
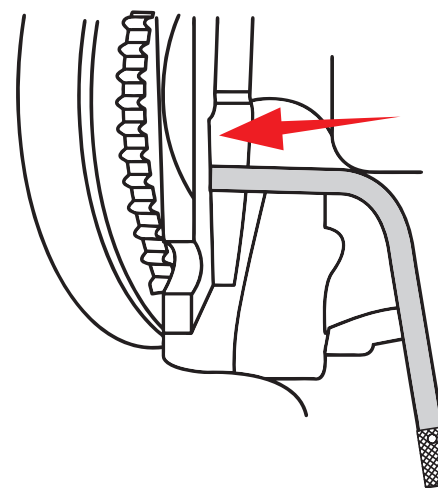
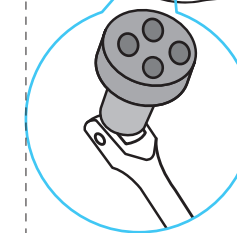
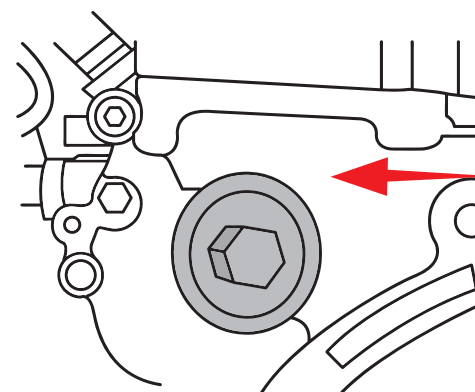
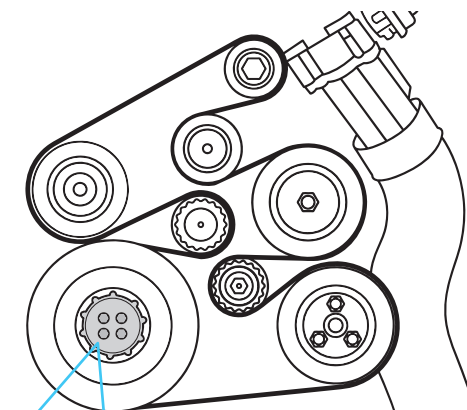
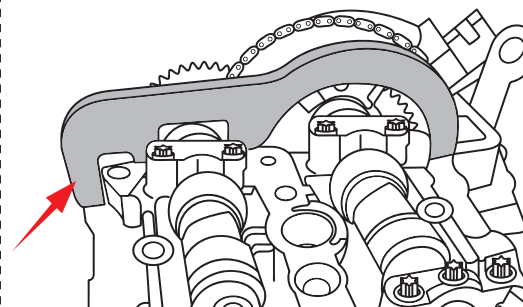

Diesel 2.0d/3.0d N47 / N47S / N57 (Ketting)

MODEL	Serie 1	Serie X
	116d/118d/120d/123d E81/82/87/88 (07-12)	X1 sDrive 18d/20d E84 (09-12) X1 xDrive 18d/20d/23d E84 (09-12)
Serie 3	316d/318d/320d/325d/330d/330xd E90/91/92/93 (07-12)	X3 20d E83 (07-10) X3 xDrive 1.8d/30d E83 (08-12)
	Serie 5	X5 30d/xDrive 40d E70 (10-12) X6 xDrive 30d/40d E71/72 (10-12)
Serie 7	520d E60/61 (07-10) 525d/530d/535d F10/11 (10-12) 530d GT/535d GT F07 (09-12)	
	730d/730Ld/740d/740d xDrive F01/02/04 (08-12)	
MOTOR	N47 / N47S	N57
	D20A D20B D20T0 D20O0 D20U0	D30U0 D30O0 D30O1 D30T0

Diesel 2.0d/3.0d N47 / N47S / N57

MODELLE	1er Serie	X Serie
	116d/118d/120d/123d E81/82/87/88 (07-12)	X1 sDrive 18d/20d E84 (09-12) X1 xDrive 18d/20d/23d E84 (09-12)
3er Serie	316d/318d/320d/325d/330d/330xd E90/91/92/93 (07-12)	X3 20d E83 (07-10) X3 xDrive 1.8d/30d E83 (08-12)
	5er Serie	X5 30d/xDrive 40d E70 (10-12) X6 xDrive 30d/40d E71/72 (10-12)
7er Serie	520d E60/61 (07-10) 525d/530d/535d F10/11 (10-12) 530d GT/535d GT F07 (09-12)	
	730d/730Ld/740d/740d xDrive F01/02/04 (08-12)	
MOTOREN	N47 / N47S	N57
	D20A D20B D20T0 D20O0 D20U0	D30U0 D30O0 D30O1 D30T0

BEINHALTET:

- A - Nockenwellen-Fixierwerkzeug
- B - Schwungscheiben-Blockierwerkzeug
- C - Kurbelwellen-Fixierdorn
- D/F - Abzieher für Einspritzdüse
- E - Werkzeug zum Halten der Riemenspannrolle

BEVAT:

- A - Vliegwiel afstelgereedschap
- B - Nokkenas uitlijn gereedschap
- C - Rotatiegereedschap voor de krukspoelie
- D/F - Trekgereedschap voor hogedruk injectiepomp
- E - Blokkeerpen

