

DIESEL ENGINE SETTING/LOCKING TOOL KIT - PUMP DUSE

- The kits includes crankshaft & camshaft locking tool, tensioner setting & adjusting tools.
- Suitable for belt drive Pump Duse diesel engines of VW group vehicles and Ford (Galaxy).
- Use to set & lock engine to make sure timing is in the correct position during timing belt replacement.
- Suggestion: Check if the tensioner is hydraulic or mechanical tensioner first. (Some of 1.2 1.4 1.9 engines were changed from hydraulic to mechanical).

MODEL

Audi	Skoda	Volkswagen
A2 (01-06)	Fabia (00-07)	Lupo(99-05)
A3 (01-09)	Fabia II (07-09)	Polo(99-07)
A4 (99-09)	Octavia (00-09)	Fox(05-08)
A5 (08-09)	Octavia II (04-09)	Jetta (05-09)
A6 (98-08)	Superb (02-08)	Passa (98-09)
TT (08-09)	Roomster (07-09)	Beetle (00-09)
Q5 (08-09)		Touran (03-09)
		Sharan (99-09)
		Caddy (03-09)
		Golf /Bora(98-08)
		Golf Plus (05-09)
		Transporter (03-09)
Ford	Seat	
Galaxy (99-06)	Arosa (99-05)	
	Altea XL(04-09)	
	Leon (00-09)	
	Toledo (04-09)	
	Alhambra (99-09)	
	Ibiza /Cordoba (02-09)	

ENGINE (Pump Duse)

1.2TDi PD ANZ, AYZ
1.4TDi PD AMF, ATL, BAY, BHC, BMS, BNM, BNV, BWB
1.9TDi PD AJM, AMG, ANU, ARL, ASZ, ATD, ATJ, AUY, AVB, AVF, AVQ, AWX, AXB, AXC, AXR, BEW, BJB, BKC, BKE, BLS, BLT, BMT, BPX, BRB, BRM, BRR, BRS, BRU, BSU, BSW, BTB, BUK, BVK, BXE, BXF
2.0TDi PD AZV, BDJ, BDK, BGW, BHW, BKD, BKP, BLB, BMA, BMM, BMN, BMP, BMR, BNA, BPW, BRC, BRE, BRF, BRT, BUZ, BE, BVF, BVG, BVH, BWV
1.9TDi PD (Ford) ANZ, ASZ, AUY

CONTENTS:

- A - Crankshaft Locking Tool (Silver / Oval)
- B - Crankshaft Locking Tool (Black / Round)
- C - Camshaft Locking Pins (2 pcs)
- D - Tensioner Adjuster (1.2, 1.4 & 1.9)
- E - Tensioner Adjuster (later 1.9 & 2.0)
- F - Tensioner Adjust Tool (Hexagon)
- G - Tensioner Locking Tool
- H - Tensioner Locking Pin (Mechanical)
- I - Tensioner Locking Tool (Hydraulic)
- J - Tensioner Setting Tool (Hydraulic)
- K - Auxiliary Belt Tensioner Locking Pin

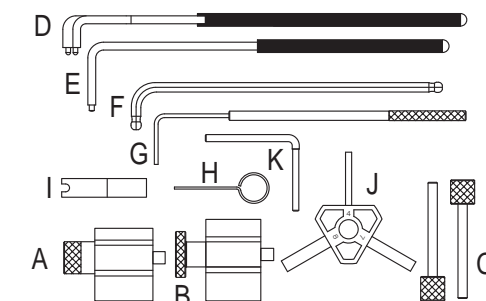

KIT DE CALAGE MOTEUR DIESEL - INJECTEURS

- Ce kit contient des outils de verrouillage d'arbre à cames et vilebrequin, ainsi qu'un ajusteur de tension.
- Compatible avec les injecteurs des moteurs à courroie diesels des marques VW group et Ford (Galaxy).
- Utilisé pour caler et verrouiller le moteur durant le remplacement de la courroie de distribution.
- Suggestion : Vérifier en premier lieu si le galet tendeur est hydraulique ou mécanique. (Certains moteurs 1.2 1.4 1.9 sont passés d'hydraulique à mécaniques)

MODELES

Audi	Skoda	Volkswagen
A2 (01-06)	Fabia (00-07)	Lupo(99-05)
A3 (01-09)	Fabia II (07-09)	Polo(99-07)
A4 (99-09)	Octavia (00-09)	Fox(05-08)
A5 (08-09)	Octavia II (04-09)	Jetta (05-09)
A6 (98-08)	Superb (02-08)	Passa (98-09)
TT (08-09)	Roomster (07-09)	Beetle (00-09)
Q5 (08-09)		Touran (03-09)
		Sharan (99-09)
		Caddy (03-09)
		Golf /Bora(98-08)
		Golf Plus (05-09)
		Transporter (03-09)
Ford	Seat	
Galaxy (99-06)	Arosa (99-05)	
	Altea XL(04-09)	
	Leon (00-09)	
	Toledo (04-09)	
	Alhambra (99-09)	
	Ibiza /Cordoba (02-09)	

MOTEURS (Injecteurs)

1.2TDi PD ANZ, AYZ
1.4TDi PD AMF, ATL, BAY, BHC, BMS, BNM, BNV, BWB
1.9TDi PD AJM, AMG, ANU, ARL, ASZ, ATD, ATJ, AUY, AVB, AVF, AVQ, AWX, AXB, AXC, AXR, BEW, BJB, BKC, BKE, BLS, BLT, BMT, BPX, BRB, BRM, BRR, BRS, BRU, BSU, BSW, BTB, BUK, BVK, BXE, BXF
2.0TDi PD AZV, BDJ, BDK, BGW, BHW, BKD, BKP, BLB, BMA, BMM, BMN, BMP, BMR, BNA, BPW, BRC, BRE, BRF, BRT, BUZ, BE, BVF, BVG, BVH, BWV
1.9TDi PD (Ford) ANZ, ASZ, AUY

CONTIENT:

- A - Outil de verrouillage vilebrequin (argenté / ovale)
- B - Outil de verrouillage vilebrequin (noir / rond)
- C - Piges de verrouillage arbre à cames (2 pcs)
- D - Ajusteur de galet tendeur (pour 1.2, 1.4 & 1.9)
- E - Ajusteur de galet tendeur (récents 1.9 & 2.0)
- F - Ajusteur de galet tendeur (Hexagonal)
- G - Outil de verrouillage galet tendeur
- H - Pige de verrouillage galet tendeur (Mécanique)
- I - Outil de verrouillage galet tendeur (Hydraulique)
- J - Outil de calage galet tendeur (Hydraulique)
- K - Pige de verrouillage galet tendeur courroie auxiliaire

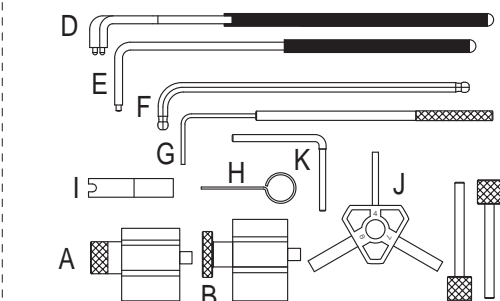

KIT DE CALADO MOTOR DIESEL - INYECTORES

- Este kit contiene herramientas de cierre de árbol de levas y cigüeñal, y un ajustador de tensión.
- Compatible con los inyectores de motores de correas diesel de las marcas VW group y Ford (galaxy).
- Se utiliza para calar y cerrar el motor durante la sustitución de la correa de distribución.
- Sugerencias: Comprobar en primer lugar si el rodillo tensor es hidráulico o mecánico. (Algunos motores 1.2/ 1.4/ 1.9 no siguen hidráulicos sino mecánicos).

MODELOS

Audi	Skoda	Volkswagen
A2 (01-06)	Fabia (00-07)	Lupo(99-05)
A3 (01-09)	Fabia II (07-09)	Polo(99-07)
A4 (99-09)	Octavia (00-09)	Fox(05-08)
A5 (08-09)	Octavia II (04-09)	Jetta (05-09)
A6 (98-08)	Superb (02-08)	Passa (98-09)
TT (08-09)	Roomster (07-09)	Beetle (00-09)
Q5 (08-09)		Touran (03-09)
		Sharan (99-09)
		Caddy (03-09)
		Golf /Bora(98-08)
		Golf Plus (05-09)
		Transporter (03-09)
Ford	Seat	
Galaxy (99-06)	Arosa (99-05)	
	Altea XL(04-09)	
	Leon (00-09)	
	Toledo (04-09)	
	Alhambra (99-09)	
	Ibiza /Cordoba (02-09)	

MOTORES (Inyectores)

1.2TDi PD ANZ, AYZ
1.4TDi PD AMF, ATL, BAY, BHC, BMS, BNM, BNV, BWB
1.9TDi PD AJM, AMG, ANU, ARL, ASZ, ATD, ATJ, AUY, AVB, AVF, AVQ, AWX, AXB, AXC, AXR, BEW, BJB, BKC, BKE, BLS, BLT, BMT, BPX, BRB, BRM, BRR, BRS, BRU, BSU, BSW, BTB, BUK, BVK, BXE, BXF
2.0TDi PD AZV, BDJ, BDK, BGW, BHW, BKD, BKP, BLB, BMA, BMM, BMN, BMP, BMR, BNA, BPW, BRC, BRE, BRF, BRT, BUZ, BE, BVF, BVG, BVH, BWV
1.9TDi PD (Ford) ANZ, ASZ, AUY

CONTIENE:

- A - Herramienta de cierre cigüeñal (plateado / oval)
- B - Herramienta de cierre cigüeñal (negro / redondo)
- C - Varillas de cierre árbol de levas (2 pzas)
- D - Ajustador de rodillo tensor (para 1.2 1.4 y 1.9)
- E - Ajustador de rodillo tensor (reciente 1.9 & 2.0)
- F - Ajustador de rodillo tensor (Hexagonal)
- G - Herramienta de cierre de rodillo tensor
- H - Varilla de cierre rodillo tensor (mecánico)
- I - Herramienta de cierre de rodillo tensor (hidráulico)
- J - Herramienta de calado rodillo tensor (hidráulico)
- K - Varilla de cierre de rodillo tensor correa auxiliar

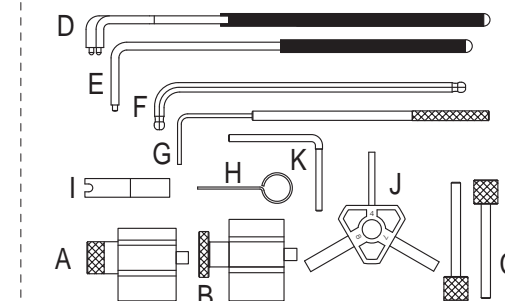

AFSTELSET DIESELMOTOREN - INJECTOREN

- Deze set bevat afstelgereedschappen voor de nokkenas en de krukas en een spanningsregelaar.
- Geschikt voor diesel injectiemotoren van VW en Ford (Galaxy).
- Gebruikt voor het afstellen van de motor tijdens het vervangen van de distributieriem.
- Raadgeving : Eerstal, controleer of de spanrol hydraulisch of mechanisch is (Wat betreft sommige 1.2 1.4 1.9 motoren, werd de hydraulische spanrol door een mechanische spanrol vervangen)

MODELLEN

Audi	Skoda	Volkswagen
A2 (01-06)	Fabia (00-07)	Lupo(99-05)
A3 (01-09)	Fabia II (07-09)	Polo(99-07)
A4 (99-09)	Octavia (00-09)	Fox(05-08)
A5 (08-09)	Octavia II (04-09)	Jetta (05-09)
A6 (98-08)	Superb (02-08)	Passa (98-09)
TT (08-09)	Roomster (07-09)	Beetle (00-09)
Q5 (08-09)		Touran (03-09)
		Sharan (99-09)
		Caddy (03-09)
		Golf /Bora(98-08)
		Golf Plus (05-09)
		Transporter (03-09)
Ford	Seat	
Galaxy (99-06)	Arosa (99-05)	
	Altea XL(04-09)	
	Leon (00-09)	
	Toledo (04-09)	
	Alhambra (99-09)	
	Ibiza /Cordoba (02-09)	

MOTOREN (Injectie)

1.2TDi PD ANZ, AYZ
1.4TDi PD AMF, ATL, BAY, BHC, BMS, BNM, BNV, BWB
1.9TDi PD AJM, AMG, ANU, ARL, ASZ, ATD, ATJ, AUY, AVB, AVF, AVQ, AWX, AXB, AXC, AXR, BEW, BJB, BKC, BKE, BLS, BLT, BMT, BPX, BRB, BRM, BRR, BRS, BRU, BSU, BSW, BTB, BUK, BVK, BXE, BXF
2.0TDi PD AZV, BDJ, BDK, BGW, BHW, BKD, BKP, BLB, BMA, BMM, BMN, BMP, BMR, BNA, BPW, BRC, BRE, BRF, BRT, BUZ, BE, BVF, BVG, BVH, BWV
1.9TDi PD (Ford) ANZ, ASZ, AUY

INHOUD:

- A - Krukas afstelgereedschap (zilver / ovaal)
- B - Krukas afstelgereedschap (zwart / rond)
- C - Afstelpen voor de nokkenas (2 stuks)
- D - Spanningsregelaar (voor 1.2, 1.4 & 1.9)
- E - Spanningsregelaar (nieuwe 1.9 & 2.0)
- F - Spanningsregelaar (Hexagonaal)
- G - Afstelgereedschap voor spanningsregelaar
- H - Afstelpen voor spanningsregelaar (Mechanisch)
- I - Afstelgereedschap voor spanningsregelaar (Hydraulisch)
- J - Afstelgereedschap voor spanningsregelaar (Hydraulisch)
- K - Afstelgereedschap voor spanningsregelaar hulpriem

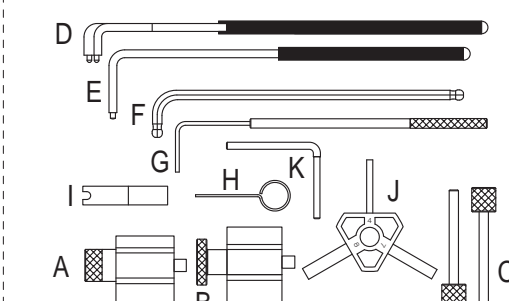

Werkzeugsortiment zur Einstellung von Dieselmotoren- Einspritzdüse

- Dieses Sortiment beinhaltet Werkzeuge zur Blockierung der Nockenwelle und der Kurbelwelle und einen Spannungseinsteller.
- Kompatibel mit den Spannungseinstellern von Dieselmotoren Zahnriemen von den Marken Volkswagen Group und Ford (Galaxy).
- Dies wird benutzt, um den Motor zu blockieren und zu einstellen während dem Wechseln von dem Zahnriemen.
- Empfehlungen : Bitte prüfen Sie erstmals, ob der Federspanner mechanisch oder hydraulisch ist (manche Motoren 1.2.1.4.1.9 sind jetzt mechanisch geworden.)

MODELLE

Audi	Skoda	Volkswagen
A2 (01-06)	Fabia (00-07)	Lupo(99-05)
A3 (01-09)	Fabia II (07-09)	Polo(99-07)
A4 (99-09)	Octavia (00-09)	Fox(05-08)
A5 (08-09)	Octavia II (04-09)	Jetta (05-09)
A6 (98-08)	Superb (02-08)	Passa (98-09)
TT (08-09)	Roomster (07-09)	Beetle (00-09)
Q5 (08-09)		Touran (03-09)
		Sharan (99-09)
		Caddy (03-09)
		Golf /Bora(98-08)
		Golf Plus (05-09)
		Transporter (03-09)
Ford	Seat	
Galaxy (99-06)	Arosa (99-05)	
	Altea XL(04-09)	
	Leon (00-09)	
	Toledo (04-09)	
	Alhambra (99-09)	
	Ibiza /Cordoba (02-09)	

MOTOREN (Einspritz)

1.2TDi PD ANZ, AYZ
1.4TDi PD AMF, ATL, BAY, BHC, BMS, BNM, BNV, BWB
1.9TDi PD AJM, AMG, ANU, ARL, ASZ, ATD, ATJ, AUY, AVB, AVF, AVQ, AWX, AXB, AXC, AXR, BEW, BJB, BKC, BKE, BLS, BLT, BMT, BPX, BRB, BRM, BRR, BRS, BRU, BSU, BSW, BTB, BUK, BVK, BXE, BXF
2.0TDi PD AZV, BDJ, BDK, BGW, BHW, BKD, BKP, BLB, BMA, BMM, BMN, BMP, BMR, BNA, BPW, BRC, BRE, BRF, BRT, BUZ, BE, BVF, BVG, BVH, BWV
1.9TDi PD (Ford) ANZ, ASZ, AUY

ENTHÄLT:

- A - Werkzeug zur Blockierung von der Kurbelwelle (silber / oval)
- B - Werkzeug zur Blockierung von der Kurbelwelle (schwarz / rund)
- C - Arretierstift zur Einstellung der Nockenwelle (2 Stück)
- D - Spannungseinsteller (für 1.2, 1.4 & 1.9)
- E - Spannungseinsteller (neu 1.9 & 2.0)
- F - Spannungseinsteller (sechseckig)
- G - Werkzeug zur Blockierung von Spannungseinstellern
- H - Werkzeug zur Blockierung von Spannungseinstellern (mechanisch)
- I - Werkzeug zur Blockierung von Spannungseinstellern (hydraulisch)
- J - Werkzeug zur Einstellung von Spannungseinstellern (hydraulisch)
- K - Arretierstift zur Einstellung von Spannungseinstellern Hilfsriemen

