



- The kit includes sprocket retaining plate, flywheel & tensioner locking pins.
- Suitable for chain drive diesel engine of Ford, Jaguar & LDV
- Use to install/remove injection pump & set/lock engine timing.

MODEL

FORD	JAGUAR	LDV
Diesel 2.0 / 2.2 / 2.4 - TDdi / TDCi DURATORQ(CHAIN)	Diesel 2.0D / 2.2D (CHAIN)	Diesel 2.4TD / TDi (CHAIN)
Mondeo (01-07) Transit (00-08)	X - Type (03-09)	Convoy (97-02)

ENGINE

FORD	JAGUAR	LDV
2.0Ddi ABFA / D3FA / F3FA	2.0D FMBA	ZSD424
2.0 TDdi D5BA / D6BA	FMBB 2.2D	
2.0 TDCi	QJBA	
FMBA / FMBB / HJBA-C / HJBE / N7BA / N7BB		
2.2 TDCi QJBA-D		
2.4 Ddi		
D2FA / D2FB / D4FA / D0FA		
2.4 TDCi		
FXFA / H9FA / H9F8 / JXFA / PHFA		

CONTENTS:

- A - Access Cover Removal Plate
- B - Sprocket Retaining Plate
- C - Location Pins (3pcs)
- D - Locking Pins (3pcs)
- E - Flywheel Locking Pin (2pcs)
- F - Tensioner Locking Pin

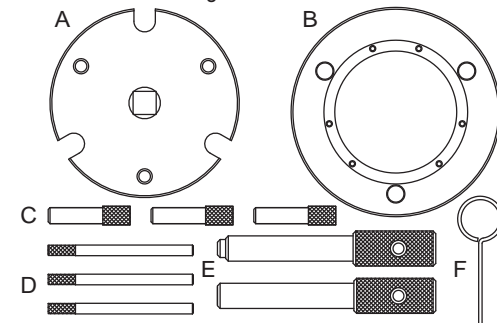

- Ce kit contient une platine de blocage des pignons, ainsi que des piges de verrouillage du volant moteur.
- Compatible pour les moteurs à chaîne diesel Ford, Jaguar et LDV.
- Utilisé pour installer/retirer la pompe à injection et verrouiller/caler le moteur.

MODELE

FORD	JAGUAR	LDV
Diesel 2.0 / 2.2 / 2.4 - TDdi / TDCi DURATORQ(CHAINE)	Diesel 2.0D / 2.2D (CHAINE)	Diesel 2.4TD / TDi (CHAINE)
Mondeo (01-07) Transit (00-08)	X - Type (03-09)	Convoy (97-02)

MOTEUR

FORD	JAGUAR	LDV
2.0Ddi ABFA / D3FA / F3FA	2.0D FMBA	ZSD424
2.0 TDdi D5BA / D6BA	FMBB 2.2D	
2.0 TDCi	QJBA	
FMBA / FMBB / HJBA-C / HJBE / N7BA / N7BB		
2.2 TDCi QJBA-D		
2.4 Ddi		
D2FA / D2FB / D4FA / D0FA		
2.4 TDCi		
FXFA / H9FA / H9F8 / JXFA / PHFA		

CONTIENT :

- A - Platine de retrait du couvercle
- B - Platine de blocage des pignons
- C - Piges d'emplacement (3pcs)
- D - Piges de verrouillage (3pcs)
- E - Pige de verrouillage volant (2pcs)
- F - Pige de tension

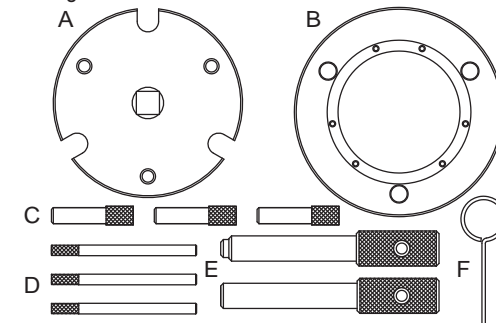

- Este kit contiene un platino de bloqueo de los piñones, y varillas de cierre del volante motor.
- Compatible con los motores de cadena diesel Ford, Jaguar y LDV.
- Útil para instalar/quitar la bomba de inyección y cerrar/calar el motor.

MODELO

FORD	JAGUAR	LDV
Diesel 2.0 / 2.2 / 2.4 - TDdi / TDCi DURATORQ(CADENA)	Diesel 2.0D / 2.2D (CADENA)	Diesel 2.4TD / TDi (CADENA)
Mondeo (01-07) Transit (00-08)	X - Type (03-09)	Convoy (97-02)

MOTOR

FORD	JAGUAR	LDV
2.0Ddi ABFA / D3FA / F3FA	2.0D FMBA	ZSD424
2.0 TDdi D5BA / D6BA	FMBB 2.2D	
2.0 TDCi	QJBA	
FMBA / FMBB / HJBA-C / HJBE / N7BA / N7BB		
2.2 TDCi QJBA-D		
2.4 Ddi		
D2FA / D2FB / D4FA / D0FA		
2.4 TDCi		
FXFA / H9FA / H9F8 / JXFA / PHFA		

CONTIENE :

- A - Platino de retirada de la tapa
- B - Platino de bloqueo de los piñones
- C - Varillas de emplazamiento (3 pzas)
- D - Varillas de cierre (3 pzas)
- E - Varilla de cierre volante (2 pzas)
- F - Varilla de tensión

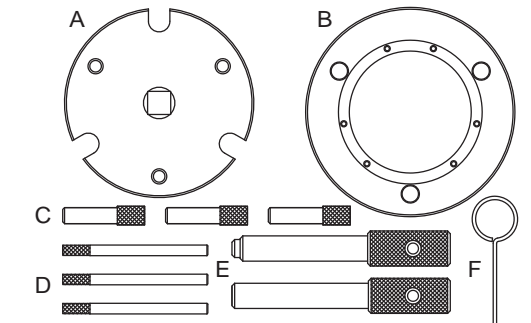

- Deze set bevat een plaat om de tandwielen in hun positie te blokkeren en een borgpen om het vliegwiel vast te houden.
- Geschikt voor dieselmotoren met ketting Ford, Jaguar en LDV.
- Gebruikt om de injectiepomp te monteren/verwijderen en om de motor te vergrendelen/af te stellen.

MODELO

FORD	JAGUAR	LDV
Diesel 2.0 / 2.2 / 2.4 - TDdi / TDCi DURATORQ (KETTING)	Diesel 2.0D / 2.2D (KETTING)	Diesel 2.4TD / TDi (KETTING)
Mondeo (01-07) Transit (00-08)	X - Type (03-09)	Convoy (97-02)

MOTOR

FORD	JAGUAR	LDV
2.0Ddi ABFA / D3FA / F3FA	2.0D FMBA	ZSD424
2.0 TDdi D5BA / D6BA	FMBB 2.2D	
2.0 TDCi	QJBA	
FMBA / FMBB / HJBA-C / HJBE / N7BA / N7BB		
2.2 TDCi QJBA-D		
2.4 Ddi		
D2FA / D2FB / D4FA / D0FA		
2.4 TDCi		
FXFA / H9FA / H9F8 / JXFA / PHFA		

INHOUD:

- A - Demontageplaat pompdeksel
- B - Blokkeerplaat voor tandwielen
- C - Stelpinnen (3 stuks)
- D - Borgpennen vliegwiel (3 stuks)
- E - Borgpen vliegwiel (2 stuks)
- F - Borgpen spanner

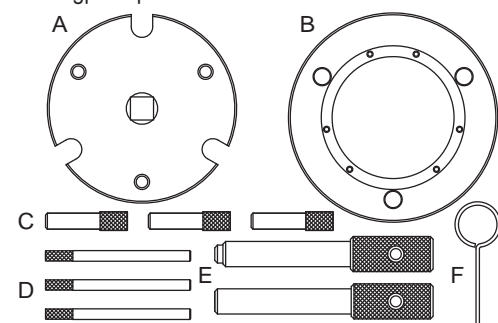

- Dieses Sortiment beinhaltet eine Einstellplatte für die Zahnräder und arretierstifte für das Schwungrad.
- Kompatibel mit Kettenmotoren Diesel Ford, Jaguar und LDV.
- Verwendung zur Installierung/Entfernung der Einspritzpumpe und zur Steuerzeiten-Einstellung/Blockierung des Motors.

MODELO

FORD	JAGUAR	LDV
Diesel 2.0 / 2.2 / 2.4 - TDdi / TDCi DURATORQ (KETTE)	Diesel 2.0D / 2.2D (KETTE)	Diesel 2.4TD / TDi (KETTE)
Mondeo (01-07) Transit (00-08)	X - Type (03-09)	Convoy (97-02)

MOTOR

FORD	JAGUAR	LDV
2.0Ddi ABFA / D3FA / F3FA	2.0D FMBA	ZSD424
2.0 TDdi D5BA / D6BA	FMBB 2.2D	
2.0 TDCi	QJBA	
FMBA / FMBB / HJBA-C / HJBE / N7BA / N7BB		
2.2 TDCi QJBA-D		
2.4 Ddi		
D2FA / D2FB / D4FA / D0FA		
2.4 TDCi		
FXFA / H9FA / H9F8 / JXFA / PHFA		

INHALT :

- A - Platte zur Deckelentfernung
- B - Einstellplatte für Zahnräder
- C - Stifte für die Einbaustelle (3 Stück)
- D - Arretierstift (3 Stück)
- E - Schwungrad-Arretierstift (2 Stück)
- F - Spannstift

