

PETROL ENGINE TWIN CAMSHAFT SETTING & LOCKING SET - VAG 1.4 / 1.6 FSI (CHAIN)

- VW petrol engine twin camshaft setting/locking tool set - vag 1.4 / 1.6 fsi (CHAIN)
- Kit de calage moteur double arbre a cames VW diesel - vag 1.4 / 1.6 fsi (CHAIN)
- Kit de calado motor doble árbol de levas VW diesel - vag 1.4/1.6 fsi (CADENA)
- Dubbele nokkenas motor afstelset VW diesel - vag 1.4 / 1.6 fsi(ketting)
- Arretierwerkzeug-satz für VW benzinmotoren (vag 1.4/1.6 fsi (kette))

3 PC.

CHAIN

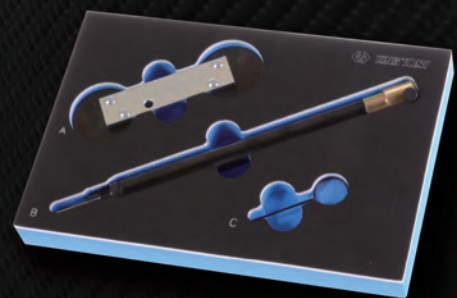

No.9AT1103E

Please wear proper safety gear while working.

VW PETROL ENGINE TWIN CAMSHAFT SETTING/ LOCKING TOOL SET - VAG 1.4 / 1.6 FSI (CHAIN)

- The kit includes camshaft setting plate, TDC position tool (with DTI) and tensioner locking pin.
- 9AT1103 'B' TDC positioning tool have to use with 9AT3-F01(not included in this set).

MODEL

| VOLKSWAGEN | AUDI | SKODA |
|--|------------|--------------------|
| Polo (02-08) Golf (03-08) Golf Plus (05-08) Jetta (06-08) Passat (05-08) Touran (03-07) | A3 (03-07) | Octavia II (04-08) |

ENGINE

| 1.4 FSi | 1.6 FSi |
|---------|---------|
| AXU | BAG |
| BKG | BLF |
| BLN | BLP |
| | BTS |

CONTENTS:

- A - Camshaft setting plate
- B - TDC position tool (with DTI)
- C - Tensioner locking pin

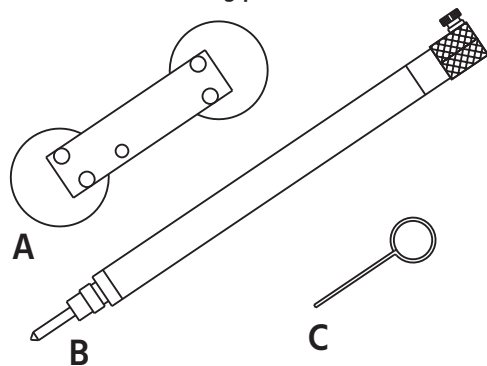

KIT DE CALAGE MOTEUR DOUBLE ARBRE A CAMES VW DIESEL - VAG 1.4 / 1.6 FSI (CHAIN)

- Ce kit contient la Platine de réglage/ blocage d'arbre à came, la Pige de blocage de tendeur, et la pige de positionnement TDC (avec DTI).
- le 9AT1103 'B' TDC doit être utilisé avec le 9AT3-F01(non inclus dans ce kit).

MODELE

| VOLKSWAGEN | AUDI | SKODA |
|--|------------|--------------------|
| Polo (02-08) Golf (03-08) Golf Plus (05-08) Jetta (06-08) Passat (05-08) Touran (03-07) | A3 (03-07) | Octavia II (04-08) |

MOTEUR

| 1.4 FSi | 1.6 FSi |
|---------|---------|
| AXU | BAG |
| BKG | BLF |
| BLN | BLP |
| | BTS |

CONTENU:

- A - Platine de réglage/ blocage d'arbre à came
- B - Pige de positionnement TDC
- C - Pige de blocage de tendeur

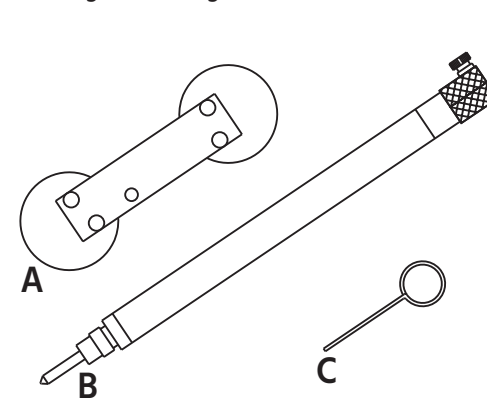

KIT DE CALADO MOTOR DOBLE ÁRBOL DE LEVAS VW DIESEL - VAG 1.4/1.6 FSI (CADENA)

- Este kit contiene el platino de reglaje/bloqueo de árbol de levas, la varilla de bloqueo del tensor, y la varilla de posicionamiento TDC (con DTI).
- El 9AT1103 « B » TDC debe ser utilizado con el 9AT3-F01 (no incluido con este kit).

MÓDELO

| VOLKSWAGEN | AUDI | SKODA |
|--|------------|--------------------|
| Polo (02-08) Golf (03-08) Golf Plus (05-08) Jetta (06-08) Passat (05-08) Touran (03-07) | A3 (03-07) | Octavia II (04-08) |

MOTORES

| 1.4 FSi | 1.6 FSi |
|---------|---------|
| AXU | BAG |
| BKG | BLF |
| BLN | BLP |
| | BTS |

CONTENIDO:

- A - Platino de reglaje/bloqueo de árbol de levas
- B - Varilla de posicionamiento TDC
- C - Varilla de bloqueo de tensor

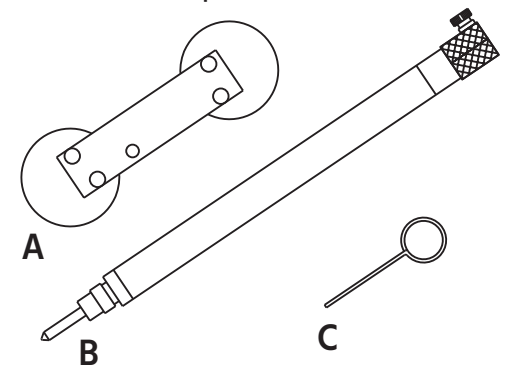

DUBBELE NOKKENAS MOTOR AFSTELSET VW DIESEL - VAG 1.4 / 1.6 FSI (KETING)

- Deze set bevat een afstelplaat voor nokkenas, een spanner borgpen, en een borgpen voor TDC-positie (met DTI).
- 9AT1103 'B' TDC moet met 9AT3-F01 (in deze set niet begrepen) worden gebruikt.

MODELLEN

| VOLKSWAGEN | AUDI | SKODA |
|--|------------|--------------------|
| Polo (02-08) Golf (03-08) Golf Plus (05-08) Jetta (06-08) Passat (05-08) Touran (03-07) | A3 (03-07) | Octavia II (04-08) |

MOTOREN

| 1.4 FSi | 1.6 FSi |
|---------|---------|
| AXU | BAG |
| BKG | BLF |
| BLN | BLP |
| | BTS |

INHOUD:

- A - Nokkenas afstelplaat
- B - Borgpen voor TDC-positie
- C - Spanner borgpen

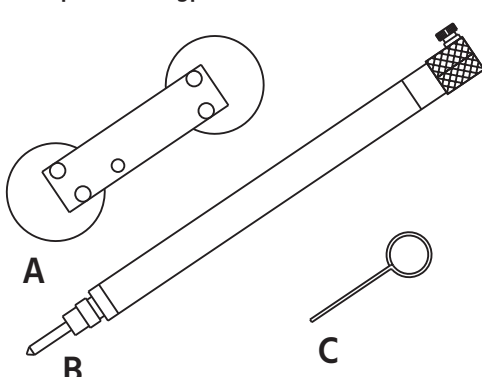

ARRETIERWERKZEUG-SATZ FÜR VW BENZINMOTOREN (VAG 1.4/1.6 FSI (KETTE))

- Der Satz enthält Nockenwellenarretierdorn, OT-Einstellung-Werkzeug und Arretierstift.
- 9AT1103-B, OT-Einstellung-Werkzeug muss mit 9AT3-F01 zusammenverwendet werden (9AT3-F01 ist nicht in diesem Satz vorhanden).

MODELL

| VOLKSWAGEN | AUDI | SKODA |
|--|------------|--------------------|
| Polo (02-08) Golf (03-08) Golf Plus (05-08) Jetta (06-08) Passat (05-08) Touran (03-07) | A3 (03-07) | Octavia II (04-08) |

MOTOR

| 1.4 FSi | 1.6 FSi |
|---------|---------|
| AXU | BAG |
| BKG | BLF |
| BLN | BLP |
| | BTS |

INHALT :

- A - Einstell-Lehre für Nockenwelle
- B - OT-Einstellung-Werkzeug
- C - Arretierstift

