

- BMW - DIESEL 2.0 / 3.0 TIMING KIT
- KIT DE CALAGE BMW - DIESEL 2.0 / 3.0
- KIT DE CALADO BMW - DIESEL 2.0 / 3.0
- BMW AFSTELSET - DIESEL 2.0 / 3.0
- OT-EINSTELLWERKZEUG FÜR BMW - DIESELMOTOR 2.0/3.0

NO. 9AT2007



www.kingtony.com

Enjoy your work

- The kit includes camshaft setting plate, tensioner retaining pin set and flywheel locking pin.
- Suitable for BMW 2.0 and 3.0 liters common rail diesel engines in BMW 3, 5 & 7 Series, X5, Land Rover Freelander, Range Rover, Rover 75.
- Use to check and adjust timing position and TDC position of camshaft and TDC position of crankshaft.

MODEL

BMW Diesel (Chain)	ROVER Diesel (Chain)	LAND ROVER Diesel (Chain)	VAUXHALL/OPEL Diesel (Chain)
118d E87 (03-07) 120d E87 (03-07)	Rover 75 (99-05) MG MG ZT (01-05)	Freelander (00-06) Td4 (2.0d) Range Rover (02-06) Td6 (3.0d)	Omega-B(01-03)
318dtd E46/E90/91(00-08) 320dtd E46/E90/91(97-08) 325d E90/91/92/93 (06-09) 330dtd/cd - E46/E90/91/92/93 (98-08) 335d E90/91/92 (06-09) 520d E39/E60/61 (99-09) 525dxd E39/E60/61 (99-09) 530dxd E39/E60/61 (98-09) 535d E60/61 (04-09) 635d E63/64 (04-09) 730dLd E38/E65/66 (98-08) X3 2.0d E83 (03-07) X3 3.0d/sd E83 (03-09) X5 3.0d E53/E70 (00-09)			

ENGINE

BMW Diesel (Chain)	ROVER Diesel (Chain)	LAND ROVER Diesel (Chain)	VAUXHALL/OPEL Diesel (Chain)
M47 / M57 M47TU / M57TU M47T2 / M57T2 20 4D 1 20 4D 4 25 6D 1 25 6D 2 30 6D 1 30 6D 2 30 6D 3 30 6D 4 30 6D 5	M47R (BMW)	204D3/Td4 (2.0 M47:BMW) 306D1/Td6 (3.0 M27:BMW)	Y25DT

- CONTENTS:**
A - Camshaft Setting Plate
B - Camshaft Plate Locking Tool
C - TDC Timing Pin
D - Tensioner Retaining Pin Set (pair)
E - Flywheel locking Pin

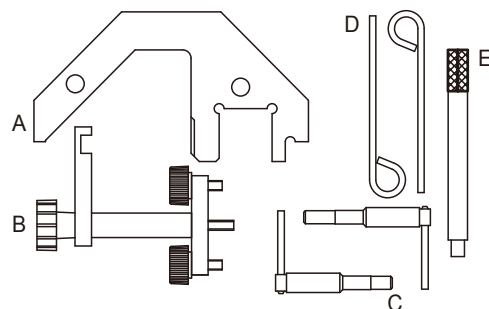

- Ce kit contient l'outil de blocage d'arbres à cames, la pign de maintien du galet tendeur, et l'outil de blocage vilebrequin.
- Compatible moteurs diesel BMW 2.0 et 3.0 litres rails communs BMW 3, 5 & 7 Series, X5, Land Rover Freelander, Range Rover, Rover 75.
- Utilisé pour vérifier et ajuster le calage de l'arbre à came et la position du vilebrequin.

MODELL

BMW Diesel (Chaine)	ROVER Diesel (Chaine)	LAND ROVER Diesel (Chaine)	VAUXHALL/OPEL Diesel (Chaine)
118d E87 (03-07) 120d E87 (03-07)	Rover 75 (99-05) MG MG ZT (01-05)	Freelander (00-06) Td4 (2.0d) Range Rover (02-06) Td6 (3.0d)	Omega-B(01-03)
318dtd E46/E90/91(00-08) 320dtd E46/E90/91(97-08) 325d E90/91/92/93 (06-09) 330dtd/cd - E46/E90/91/92/93 (98-08) 335d E90/91/92 (06-09) 520d E39/E60/61 (99-09) 525dxd E39/E60/61 (99-09) 530dxd E39/E60/61 (98-09) 535d E60/61 (04-09) 635d E63/64 (04-09) 730dLd E38/E65/66 (98-08) X3 2.0d E83 (03-07) X3 3.0d/sd E83 (03-09) X5 3.0d E53/E70 (00-09)			

MOTEUR

BMW Diesel (Chaine)	ROVER Diesel (Chaine)	LAND ROVER Diesel (Chaine)	VAUXHALL/OPEL Diesel (Chaine)
M47 / M57 M47TU / M57TU M47T2 / M57T2 20 4D 1 20 4D 4 25 6D 1 25 6D 2 30 6D 1 30 6D 2 30 6D 3 30 6D 4 30 6D 5	M47R (BMW)	204D3/Td4 (2.0 M47:BMW) 306D1/Td6 (3.0 M27:BMW)	Y25DT

- CONTIENT :**
A - Blocage d'arbre à came
B - outil de calage
C - pign de maintien
D - pign de maintien du galet tendeur
E - blocage vilebrequin

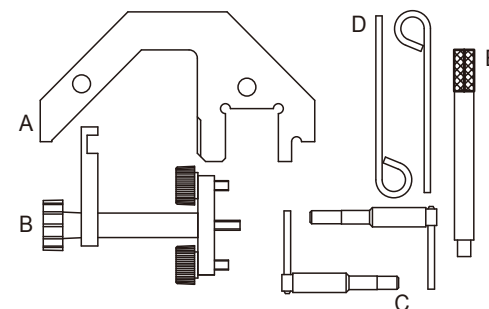

- Este kit contiene la herramienta de bloqueo de árbol de levas, la varilla para aguantar el rodillo tensor, y la herramienta de bloqueo berbiqui.
- Compatible motores diesel BMW 2.0 y 3.0 litros rieles comunes BMW 3, 5 & 7 Series, X5, Land Rover Freelander, Range Rover, Rover 75.
- Útil para comprobar y arreglar el calado del árbol de levas y la posición del berbiqui.

MÓDELO

BMW Diesel (Cadena)	ROVER Diesel (Cadena)	LAND ROVER Diesel (Cadena)	VAUXHALL/OPEL Diesel (Cadena)
118d E87 (03-07) 120d E87 (03-07)	Rover 75 (99-05) MG MG ZT (01-05)	Freelander (00-06) Td4 (2.0d) Range Rover (02-06) Td6 (3.0d)	Omega-B(01-03)
318dtd E46/E90/91(00-08) 320dtd E46/E90/91(97-08) 325d E90/91/92/93 (06-09) 330dtd/cd - E46/E90/91/92/93 (98-08) 335d E90/91/92 (06-09) 520d E39/E60/61 (99-09) 525dxd E39/E60/61 (99-09) 530dxd E39/E60/61 (98-09) 535d E60/61 (04-09) 635d E63/64 (04-09) 730dLd E38/E65/66 (98-08) X3 2.0d E83 (03-07) X3 3.0d/sd E83 (03-09) X5 3.0d E53/E70 (00-09)			

MOTOR

BMW Diesel (Cadena)	ROVER Diesel (Cadena)	LAND ROVER Diesel (Cadena)	VAUXHALL/OPEL Diesel (Cadena)
M47 / M57 M47TU / M57TU M47T2 / M57T2 20 4D 1 20 4D 4 25 6D 1 25 6D 2 30 6D 1 30 6D 2 30 6D 3 30 6D 4 30 6D 5	M47R (BMW)	204D3/Td4 (2.0 M47:BMW) 306D1/Td6 (3.0 M27:BMW)	Y25DT

- CONTIENE :**
A - bloqueo de árbol de levas
B - Herramienta de calado
C - Varilla para aguantar el rodillo tensor
D - Varilla para aguantar el rodillo tensor
E - Bloqueo berbiqui

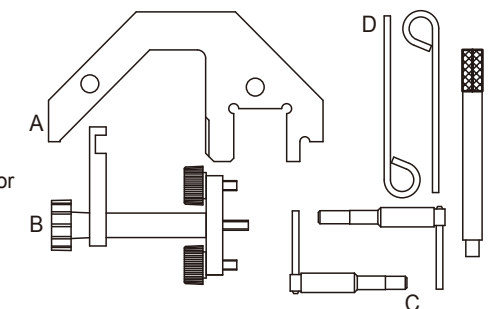

- Deze set bevat een afstelset voor nokkenas, een borgpen om de spanrol vast te houden, en een blokkeergereedschap voor de krukas.
- Geschikt voor BMW 2.0 et 3.0L dieselmotoren met common-rails BMW 3, 5 & 7 Series, X5, Land Rover Freelander, Range Rover, Rover 75.
- Gebruikt om de nokkenas afstelling en de krukas positie te controleren en gelijk te maken.

MODELLEN

BMW Diesel (Ketting)	ROVER Diesel (Ketting)	LAND ROVER Diesel (Ketting)	VAUXHALL/OPEL Diesel (Ketting)
118d E87 (03-07) 120d E87 (03-07)	Rover 75 (99-05) MG MG ZT (01-05)	Freelander (00-06) Td4 (2.0d) Range Rover (02-06) Td6 (3.0d)	Omega-B(01-03)
318dtd E46/E90/91(00-08) 320dtd E46/E90/91(97-08) 325d E90/91/92/93 (06-09) 330dtd/cd - E46/E90/91/92/93 (98-08) 335d E90/91/92 (06-09) 520d E39/E60/61 (99-09) 525dxd E39/E60/61 (99-09) 530dxd E39/E60/61 (98-09) 535d E60/61 (04-09) 635d E63/64 (04-09) 730dLd E38/E65/66 (98-08) X3 2.0d E83 (03-07) X3 3.0d/sd E83 (03-09) X5 3.0d E53/E70 (00-09)			

MOTOREN

BMW Diesel (Ketting)	ROVER Diesel (Ketting)	LAND ROVER Diesel (Ketting)	VAUXHALL/OPEL Diesel (Ketting)
M47 / M57 M47TU / M57TU M47T2 / M57T2 20 4D 1 20 4D 4 25 6D 1 25 6D 2 30 6D 1 30 6D 2 30 6D 3 30 6D 4 30 6D 5	M47R (BMW)	204D3/Td4 (2.0 M47:BMW) 306D1/Td6 (3.0 M27:BMW)	Y25DT

- INHOUD:**
A - Afstelgereedschap voor nokkenas
B - Afstelgereedschap
C - Borgpen
D - Borgpen om de spanrol vast te houden
E - Blokkeergereedschap voor de krukas

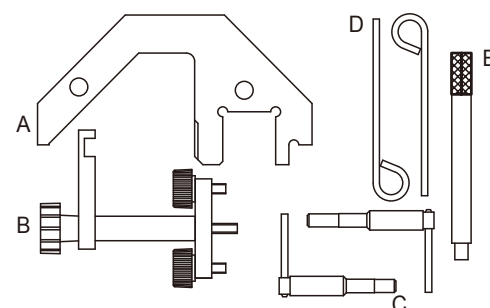

- Der Satz enthält Nockenwellen-Einstellwerkzeug, Spanner-Halterstiftset und Kurbelwellen-OT-Arretierdorn.
- Passend für BMW 2.0 und 3.0L Common-Rail-Dieselmotoren im BMW 3er, 5er und 7er, X5, Land Rover Freelander, Range Rover und Rover75.
- Erforderlich beim Überprüfen und Einstellen des OT- Stellung der Nockenwelle und der Kurbelwelle.

MODELL

BMW Diesel (Kette)	ROVER Diesel (Kette)	LAND ROVER Diesel (Kette)	VAUXHALL/OPEL Diesel (Kette)
118d E87 (03-07) 120d E87 (03-07)	Rover 75 (99-05) MG MG ZT (01-05)	Freelander (00-06) Td4 (2.0d) Range Rover (02-06) Td6 (3.0d)	Omega-B(01-03)
318dtd E46/E90/91(00-08) 320dtd E46/E90/91(97-08) 325d E90/91/92/93 (06-09) 330dtd/cd - E46/E90/91/92/93 (98-08) 335d E90/91/92 (06-09) 520d E39/E60/61 (99-09) 525dxd E39/E60/61 (99-09) 530dxd E39/E60/61 (98-09) 535d E60/61 (04-09) 635d E63/64 (04-09) 730dLd E38/E65/66 (98-08) X3 2.0d E83 (03-07) X3 3.0d/sd E83 (03-09) X5 3.0d E53/E70 (00-09)			

MOTOREN

BMW Diesel (Kette)	ROVER Diesel (Kette)	LAND ROVER Diesel (Kette)	VAUXHALL/OPEL Diesel (Kette)
M47 / M57 M47TU / M57TU M47T2 / M57T2 20 4D 1 20 4D 4 25 6D 1 25 6D 2 30 6D 1 30 6D 2 30 6D 3 30 6D 4 30 6D 5	M47R (BMW)	204D3/Td4 (2.0 M47:BMW) 306D1/Td6 (3.0 M27:BMW)	Y25DT

- INHALT :**
A - Nockenwellen-Einstellplatte.
B - Nockenwellen-Platte-Arretierwerkzeuge
C - OT-Stellung-Arretierdorn (Satz)
D - Spanner-Halterstift (Satz)
E - Kurbelwellen-OT-Arretierdorn

